



Customer: CANADIAN NATURAL RES. Description: VERTICAL SEPARATOR

Facility: KNOPCIK SWEET Location: 08-11-75-12 W6M

Reg A#: 492937 Serial #: 3154-V3 Drawing#: 2

CRN #: P0994.213 Manufacturer: PLAINS OIL LTD. Unit #: N/A Year Built: 2003

Shell MAWP: 10204 kPa Shell MAWT: 38°C Shell Material: SA 106 B Nominal: 21.4mm CA: 1.6mm

Tube "A" MAWP: _____ Tube "A" MAWT: _____ Head Material: SA 516 70N Nominal: 15.9mm CA: 1.6mm

Tube "B" MAWP: _____ Tube "B" MAWT: _____ Tube Material: _____ Nominal: _____ CA: _____

Size: 16" x 7' Manway: NO MDMT: -29°C Boot Shell Mat: _____ Nominal: _____ CA: _____

Insulated: NO C Stamp: N/S RT: 2 PWHT: NO Boot Head Mat: _____ Nominal: _____ CA: _____

PSV DATA

Manufacturer: TAYLOR Serviced By: ROCKY MTN. VALVE

Model: T-8200-1 Service Date: 7/2/2008

Serial: 5272-5 Code Stamp: UV

Set Pressure: 1379 kPa CRN: OG1316.2C

Capacity: 761 scfm Location: SHELL

Tag: N/S Inlet Size: 1" M.T

Flows To: ATMOS. Outlet Size: 1" F.T

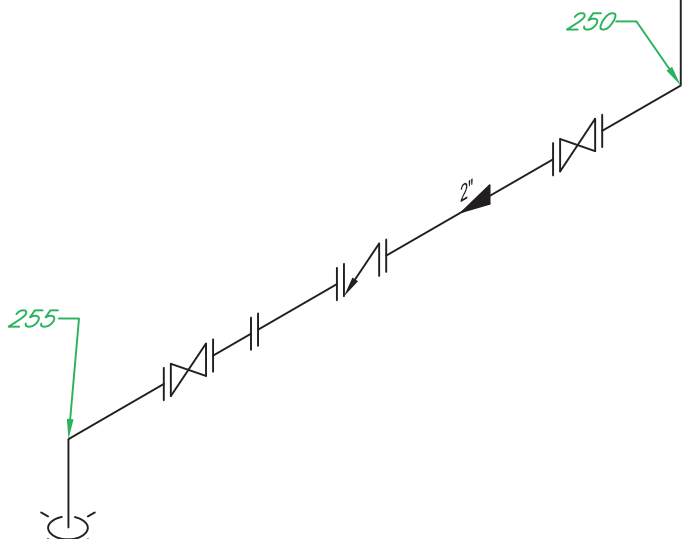
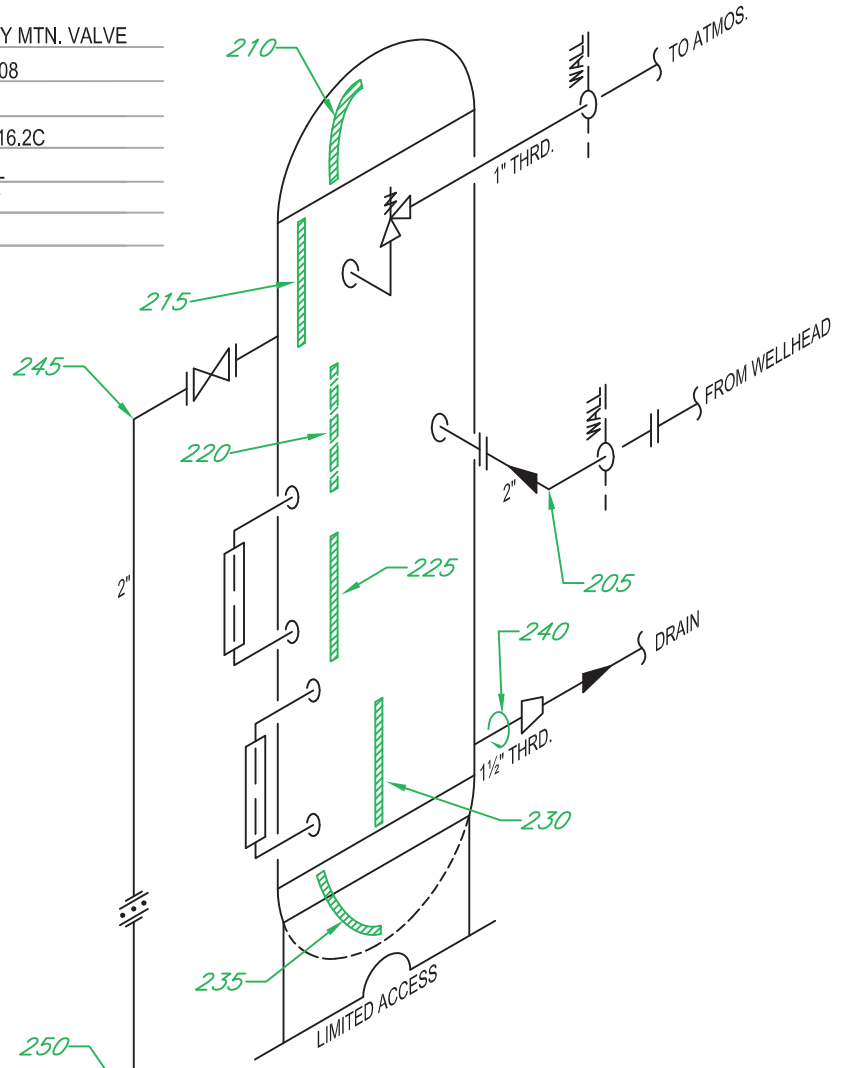



UTS Data Sheet

Client: **Canadian Natural Resources**
 Facility: **Knopcik Sweet**
 LSD: **08-11-75-12 w6m**
 Equip Description: **Vertical Separator**
 Reg A#: **492937**
 Drawing #: **2**

			Nominal Thickness (mm)	Corrosion Allowance (mm)	Flag Thickness (mm)
205	Description: 2" 90° Elbow		5.5	0.7	4.8
	Date: Dec 8, 08	Nov 17, 11			
	Minimum: 4.9	4.9			
	Average: 5.3	5.3			
	Comments:				
210	Description: Top Head		15.9	1.6	14.3
	Date: Dec 8, 08	Nov 17, 11			
	Minimum: 18.1	18.1			
	Average: 18.7	18.7			
	Comments: <i>Min scan at knuckle.</i>				
215	Description: Upper Shell		21.4	1.6	19.8
	Date: Dec 8, 08	Nov 17, 11			
	Minimum: 20.8	20.8			
	Average: 20.9	20.9			
	Comments:				
220	Description: Mid Shell		21.4	1.6	19.8
	Date: Dec 8, 08	Nov 17, 11			
	Minimum: 21.5	21.5			
	Average: 21.7	21.7			
	Comments:				
225	Description: Mid Shell		21.4	1.6	19.8
	Date: Dec 8, 08	Nov 17, 11			
	Minimum: 21.1	21.1			
	Average: 21.3	21.3			
	Comments:				
230	Description: Lower Shell		21.4	1.6	19.8
	Date: Dec 8, 08	Nov 17, 11			
	Minimum: 21.1	21.0			
	Average: 21.5	21.3			
	Comments: <i>Min scan at top of band.</i>				
235	Description: Bottom Head		15.9	1.6	14.3
	Date: Dec 8, 08	Nov 17, 11			
	Minimum: 18.7	18.6			
	Average: 19.1	19.0			
	Comments: <i>Nov 2011_Limited access.</i>				
240	Description: 1½" Circ Band		5.1	0.6	4.5
	Date: Dec 8, 08	Nov 17, 11			
	Minimum: 5.8	5.8			
	Average: 6.3	6.3			
	Comments:				



UTS Data Sheet

Client: **Canadian Natural Resources**
 Facility: **Knopcik Sweet**
 LSD: **08-11-75-12 w6m**
 Equip Description: **Vertical Separator**
 Reg A#: **492937**
 Drawing #: **2**

			Nominal Thickness (mm)	Corrosion Allowance (mm)	Flag Thickness (mm)
245	Description: 2" 90° Elbow		5.5	0.7	4.8
	Date:	Dec 8, 08 Nov 17, 11			
	Minimum:	5.3 5.1			
	Average:	5.8 5.4			
	Comments:				
250	Description: 2" 90° Elbow		5.5	0.7	4.8
	Date:	Dec 8, 08 Nov 17, 11			
	Minimum:	5.1 4.9			
	Average:	5.4 5.3			
	Comments:	<i>Min scan at mid elbow, limited access due to pipe support.</i>			
255	Description: 2" 90° Elbow		5.5	0.7	4.8
	Date:	Dec 8, 08 Nov 17, 11			
	Minimum:	5.0 4.9			
	Average:	5.3 5.2			
	Comments:				