

**HIGH PRESSURE FLARE KNOCKOUT DRUM**  
NO INFORMATION AVAILABLE

**H-610 BUILDING HEATER**  
NO INFORMATION AVAILABLE  
DATE: 22.000 BTU/HR

**V-610 LOW PRESSURE FLARE KNOCKOUT DRUM**

SIZE: 1220 mm dia x 396 mm H/A  
MFG: SWTCH INDUSTRIES LTD.  
S/N: SWI-075  
MFG: SWTCH INDUSTRIES LTD.

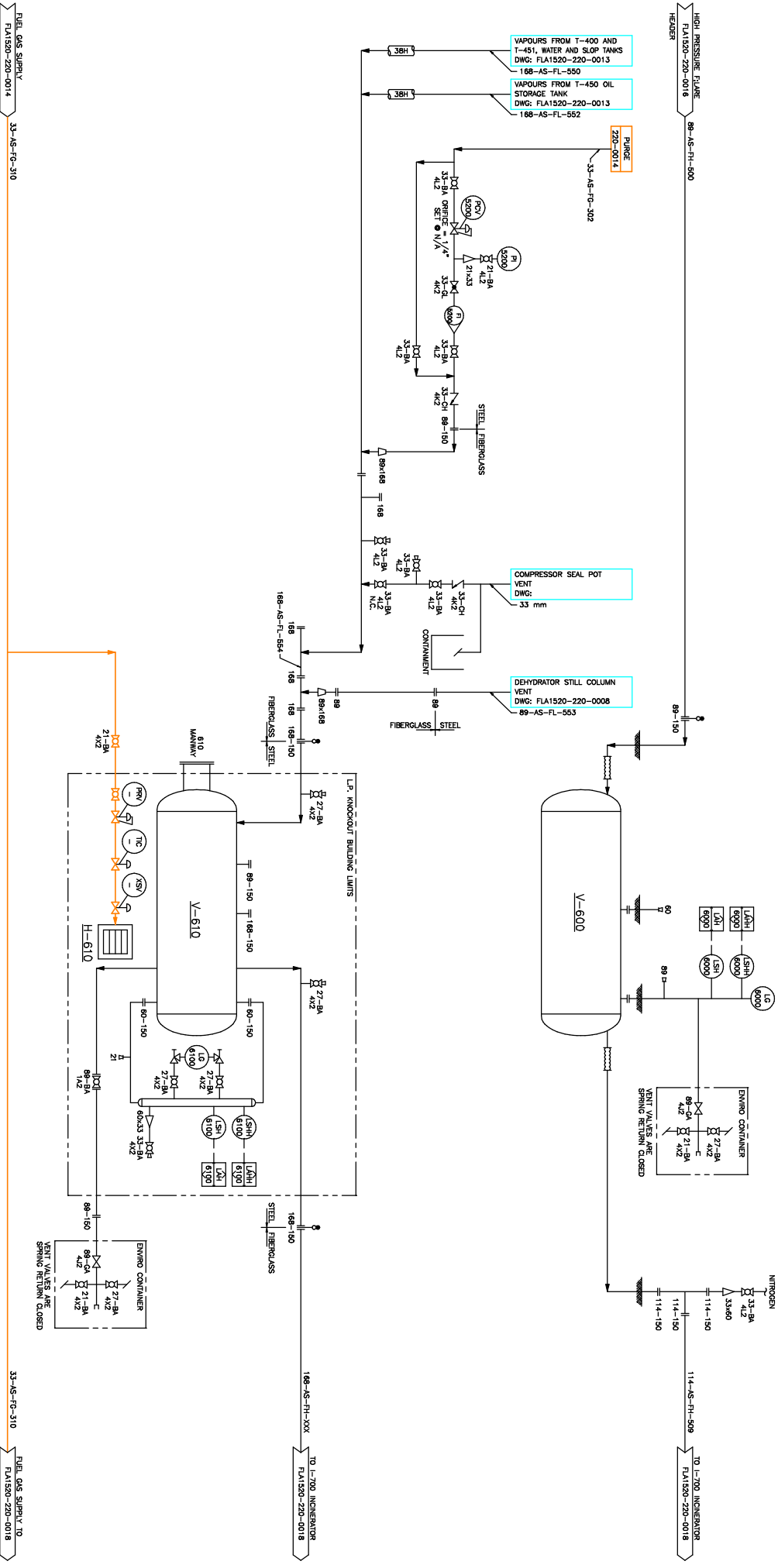

FUEL GAS SUPPLY TO FLA1520-220-0014

FUEL GAS SUPPLY TO FLA1520-220-0017

REV.	DESCRIPTION	DATE	BY	CHK	APP.	CLIENT
1	AS IS AS PER FIELD VIST	28 06 12	WMA			

DATE	DRAWN BY	DESIGNED BY	CHECKED BY	APPROVED BY	SCALE	TITLE
28 06 2012	WMA					H.P. AND L.P. FLARE KNOCKOUTS PROCESS AND INSTRUMENTATION DIAGRAM

DATE	BY	CHK	APP.	CLIENT
28 06 12	WMA			

REV.	DESCRIPTION	DATE	BY	CHK	APP.	CLIENT
1	AS IS AS PER FIELD VIST	28 06 12	WMA			

DRAWING NO. REFERENCE DRAWINGS

NDISL

CONCEPT NATURE  
15-20-85-17 W6M  
PROCESS AND INSTRUMENTATION DIAGRAM  
DRAWING NO. FLA1520-220-0017  
REV. 1