

P&ID. # \_\_\_\_\_  
REF. # \_\_\_\_\_

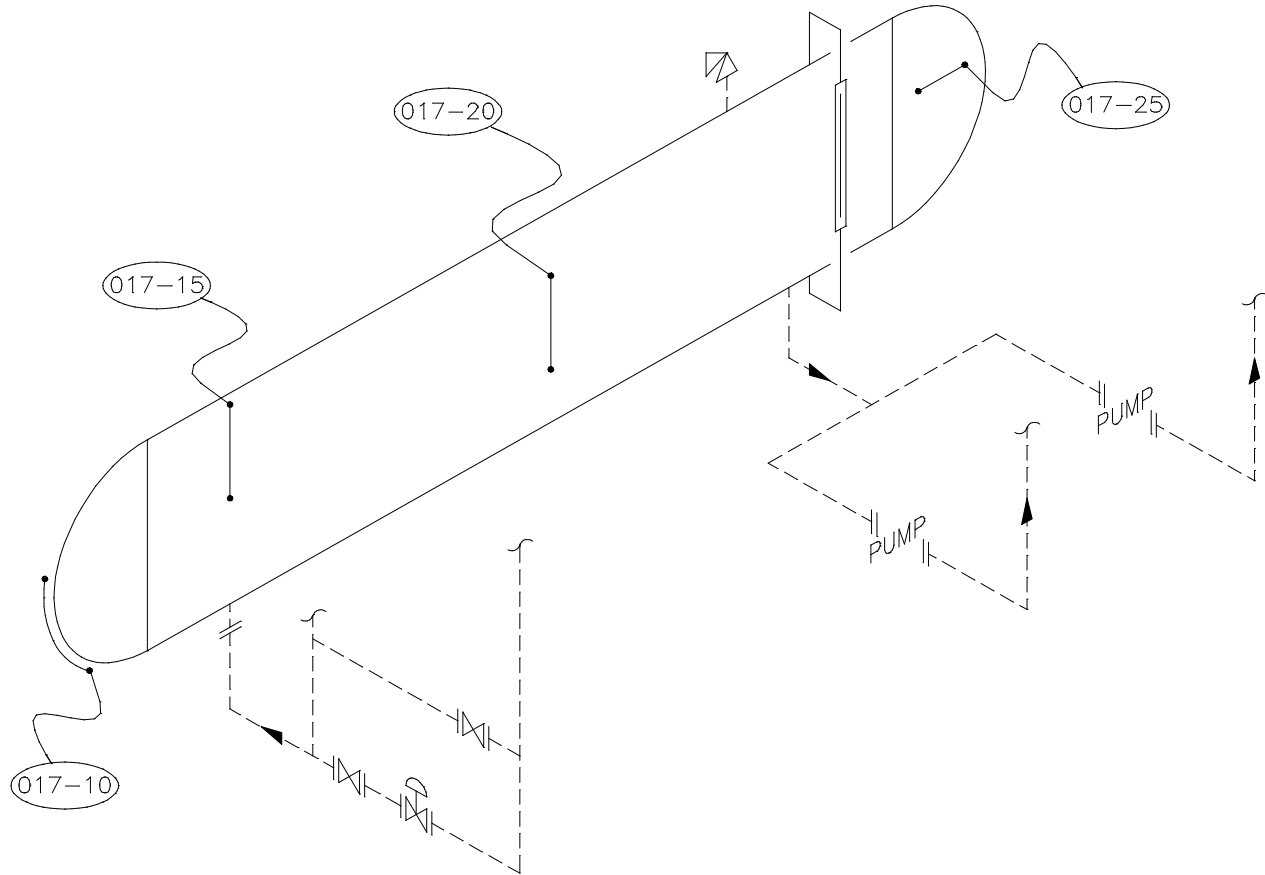

### VESSEL DATA

P.E. No. V-15 Serial No. N/S Prov. Reg. No. A0176623 C.R.N. E3431.2  
MFR. HYCON Code/Div. N/S Para N/S Code Stamp U  
Yr. Bilt. 1982 M/W (Y/N) N/S Size \_\_\_\_\_ Service SWEET PWHT N/S  
RT 2 Insulated YES

### Nominal Thickness & Material

Head: 6.4mm Mat'l: SA-516-70N C.A.: 1.6mm  
Head: \_\_\_\_\_  
Shell: 6.4mm SA-516-70N 1.6mm  
Shell: \_\_\_\_\_  
Chan Hd: \_\_\_\_\_  
Chan Sh: \_\_\_\_\_  
Boot Hd: \_\_\_\_\_  
Boot Sh: \_\_\_\_\_

MAWP Shell Side 150PSI @ Temp. 550°F  
MAWP Tube Side \_\_\_\_\_ @ Temp. \_\_\_\_\_

COMMENTS: 2011/02 - OUT OF SERVICE

Repairs \_\_\_\_\_  
Reason \_\_\_\_\_  
Reason \_\_\_\_\_

APACHE CORPORATION  
CHINCHAGA GAS PLANT #2  
LSD 01-24-096-05W6M

### HOT OIL SURGE TANK

TECH.: M.M.	REV. DATE: 2011/02	DWG DATE: 2002/12
CAD: A.L.	REVISION: 2	DRAWING: 017