

P&ID. # \_\_\_\_\_  
REF. # \_\_\_\_\_

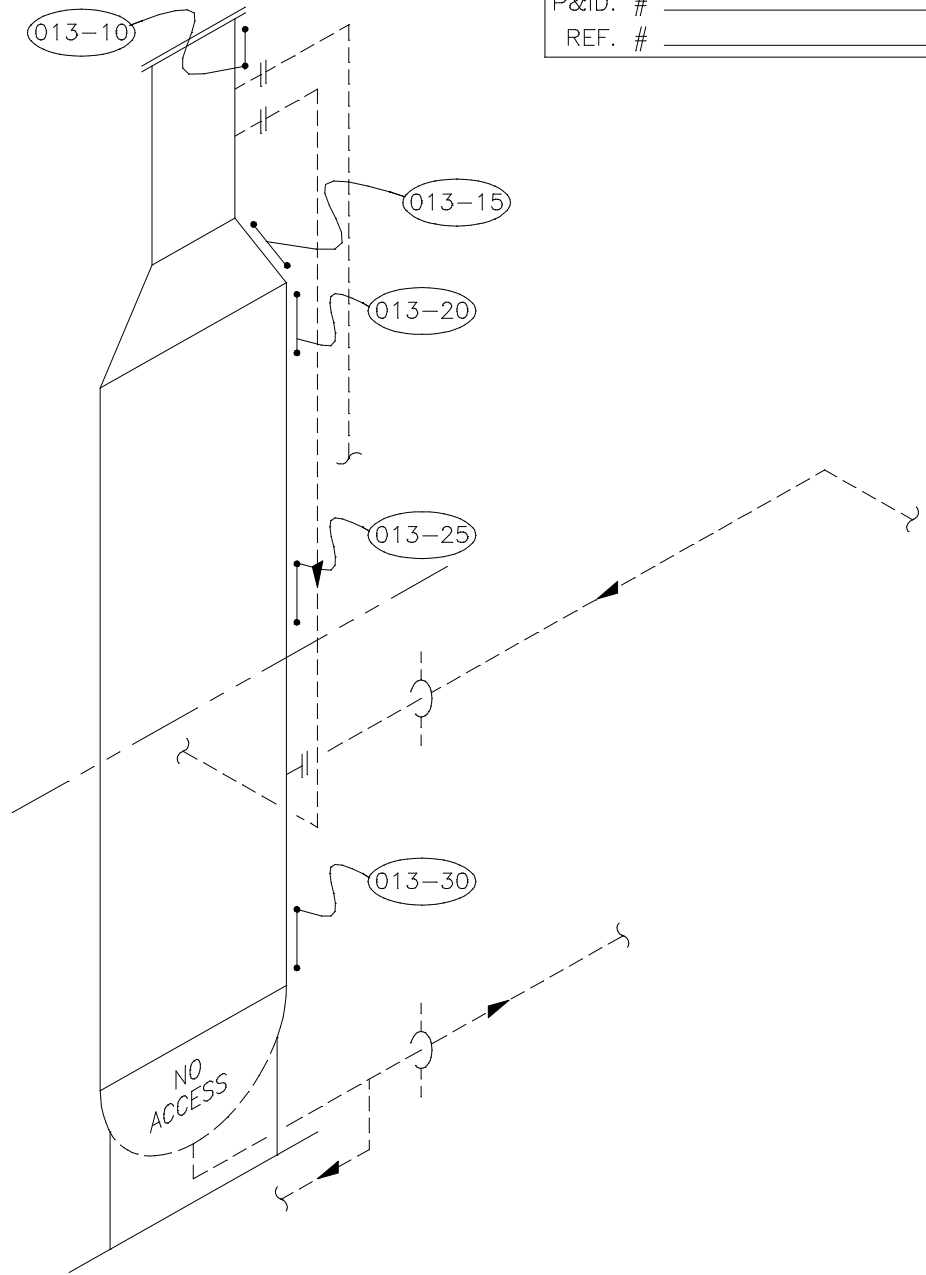

### VESSEL DATA

P.E. No.           N/S           Serial No.           N/S           Prov. Reg. No.           A0201355           C.R.N.           E4357.2            
MFR.           DACRO           Code/Div.           N/S           Para           N/S           Code Stamp           U            
Yr. Bilt.           1982           M/W (Y/N)           N/S           Size                            Service           SWEET           PWHT           N/S            
RT           2           Insulated           YES          

### Nominal Thickness & Material

Head:           21.3mm           Mat'l:           SA-516-70           C.A.:           1.6mm            
Head:                                                                                   
Shell:           12.7mm                     SA-516-70                     N/S            
Shell:           22.2mm                     SA-516-70                                       
Chan Hd:                                                                                   
Chan Sh:                                                                                   
Boot Hd:                                                                                   
Boot Sh:                                                                                   
MAWP Shell Side           N/S           @ Temp.           N/S            
MAWP Tube Side                            @ Temp.                           

Repairs                             
Reason                             
Reason                           

APACHE CORPORATION  
CHINCHAGA GAS PLANT #2  
LSD 01-24-096-05W6M

### DE-ETHANIZER TOWER

COMMENTS:           2011/02 - OUT OF SERVICE          

TECH.: M.M.	REV. DATE: 2011/02	DWG DATE: 2002/12
CAD: A.L.	REVISION: 2	DRAWING: 013