

P&ID. # \_\_\_\_\_  
REF. # \_\_\_\_\_

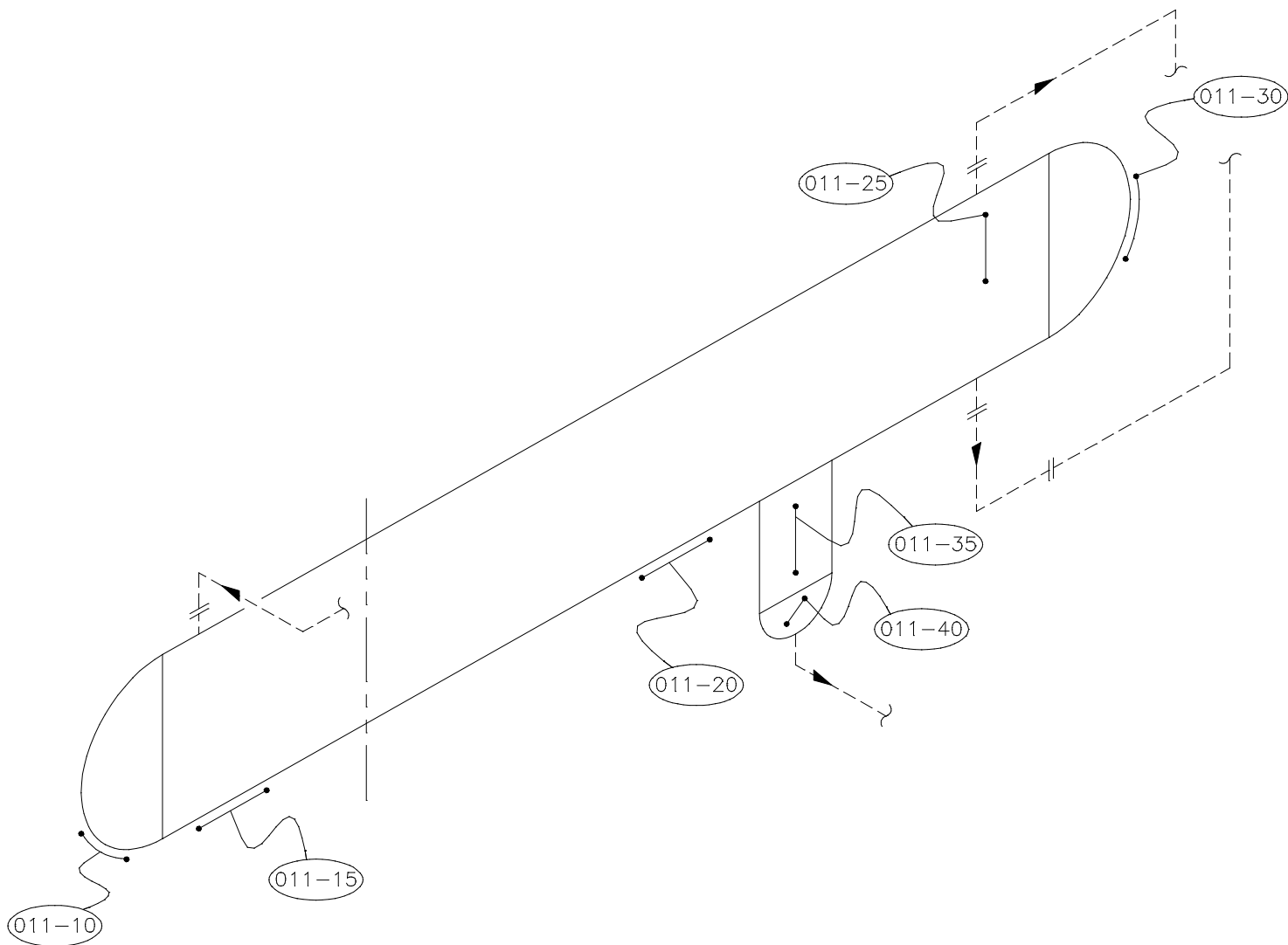

### VESSEL DATA

P.E. No. V-2A Serial No. N/S Prov. Reg. No. A0227076 C.R.N. F5231.2  
MFR. PROPAK Code/Div. N/S Para N/S Code Stamp U  
Yr. Bilt. 1985 M/W (Y/N) N/S Size N/S Service SWEET PWHT N/S  
RT 1 Insulated PARTIAL

### Nominal Thickness & Material

Head: 43.99mm Mat'l: N/S C.A.: N/S  
Head: \_\_\_\_\_  
Shell: 44.50mm N/S N/S  
Shell: \_\_\_\_\_  
Chan Hd: \_\_\_\_\_  
Chan Sh: \_\_\_\_\_  
Boot Hd: \_\_\_\_\_  
Boot Sh: \_\_\_\_\_

MAWP Shell Side 1150PSI @ Temp. 150°F  
MAWP Tube Side \_\_\_\_\_ @ Temp. \_\_\_\_\_

COMMENTS: 2011/02 - OUT OF SERVICE

Repairs \_\_\_\_\_  
Reason \_\_\_\_\_  
Reason \_\_\_\_\_

APACHE CORPORATION  
CHINCHAGA GAS PLANT #2  
LSD 01-24-096-05W6M

### DE-ETHANIZER FEED DRUM

TECH.: M.M.	REV. DATE: 2011/02	DWG DATE: 1999/11
CAD: A.L.	REVISION: 2	DRAWING: 011