

PLEASE NOTE: SEAL WELD TOP SIDE OF L-SKID SADDLES @ SHELL

LADDER SHOWN SEPARATE FROM TANK FOR CLARITY ONLY (FOLD HOOP DOWN FOR SHIPMENT)

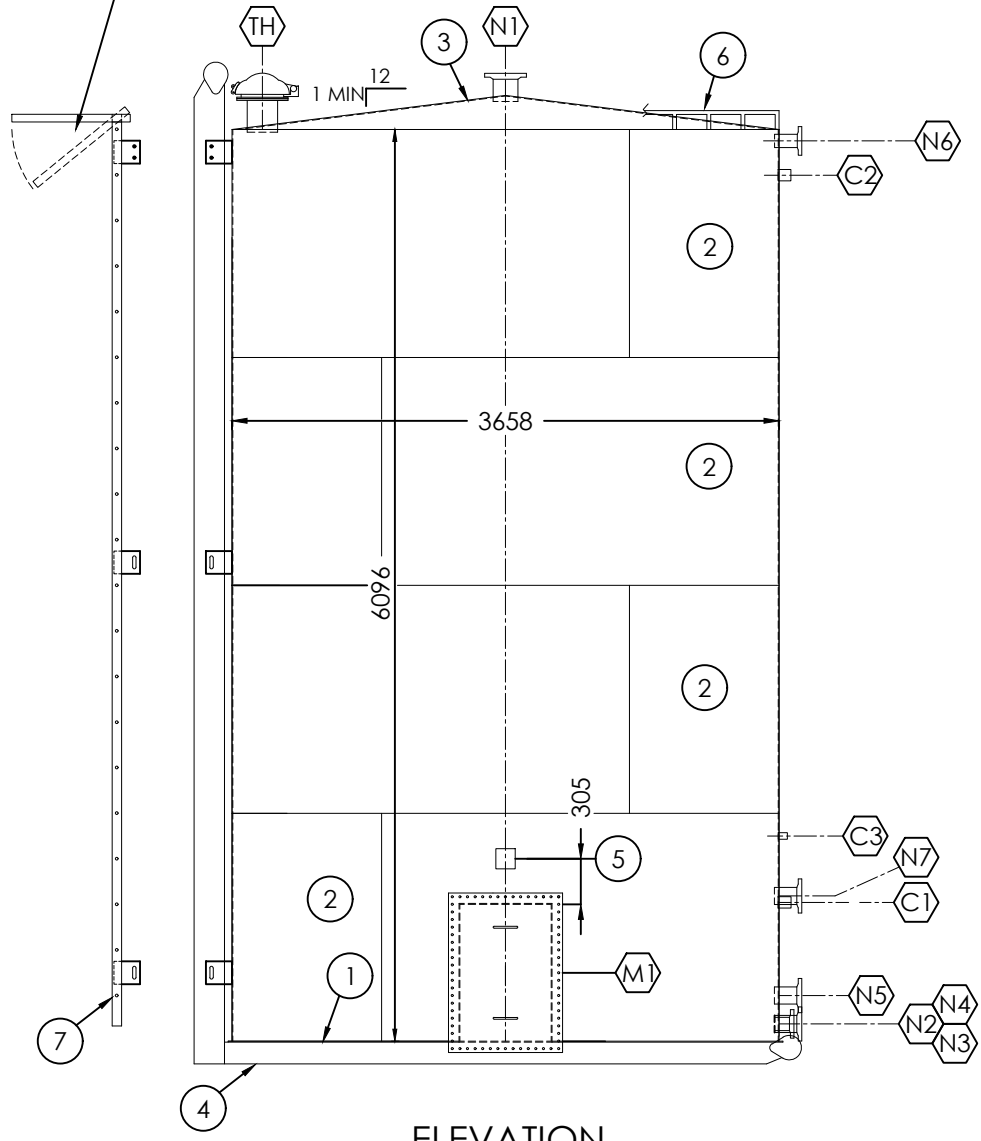

ELEVATION

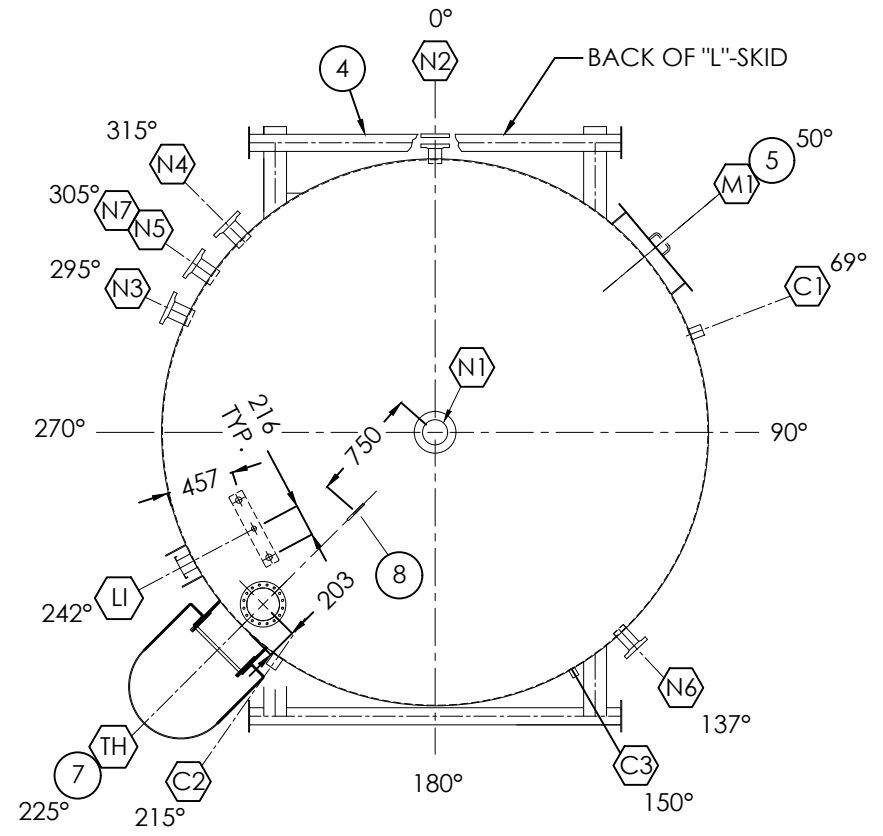

ORIENTATION

BILL OF MATERIALS (FOR 1 TANK)				
MARK	QTY	MAT'L	DESCRIPTION	SERVICE
1	1	A36	6.4 PL. x 3710 DIA. FLAT BOTTOM	
2	4	A36	4.8 PL. x 1524 x 11492 LG. SHELLS	
3	1	A36	4.8 PL. x 3671 DIA. CONED ROOF	
4	1	A36	STRUCTURAL L-SKID (SEE SHT. B-17577-86 SK FOR DETAILS)	
5	1		NAMEPLATE & BRACKET	
6	1	A36	400 BBL SAFETY TOE RAIL	
7	1	A36/44W	LADDER & SAFETY HOOP (SEE SHT. B-17577-86 LD FOR DETAILS)	
8	1	A36/44W	FALL ARREST SYSTEM TO BE INSTALLED PRIOR TO SHIPMENT LANYARD TIE OFF LUG (ARGO STD TAIL LUG - NO REPAD)	
M1	1	A36	610 x 914 [24" x 36"] RECT. MANWAY (LAPPED ON FLOOR)	
	1	A36	762 x 1066 RECT. MANWAY COVER	
TH	1		219 DIA. (8") ENARDO 330 SWEET SERVICE THIEF HATCH SET @ 16 OZ. PRESS/0.4 OZ. VAC.	
	1	A106	8" ARGO FAB. THIEF HATCH EXTENSION	
LI	1	316SS	33 DIA. (1") 3000# FS CPLG	LEVEL INDICATOR
	2	316SS	42 DIA. (1 1/4") 3000# FS CPLG	
	1		AMGAS SOUR SERVICE GAUGE SYSTEM w/ COMPLETE ASSEMBLY & METRIC LEVEL GAUGE BOARD & PVC FLOATS	
C1	1	316SS	60 DIA. (2") NPT 3000# FULL CPLG	FUTURE LLSD
C2	1	316SS	60 DIA. (2") NPT 3000# FULL CPLG	FUTURE HLSD
C3	1	316SS	33 DIA. (1") NPT 3000# FULL CPLG	FUTURE TI
N1	1	A105	168 DIA. (6") 150# RFSO FLANGE	VENT
	1	A106	168 DIA. (6") SCH STD SMLS PIPE x 175 LG	
N2	1	A105	89 DIA. (3") 150# RFSO FLANGE	DRAIN
	1	A106	89 DIA. (3") SCH STD SMLS PIPE x 116 LG	
	1	A105	89 DIA. (3") 150# RFSO BLIND FLANGE	
N3	1	A105	114 DIA. (4") 150# RFSO FLANGE	INLET
	1	A106	114 DIA. (4") SCH STD SMLS PIPE x 168 LG	
N4	1	A105	114 DIA. (4") 150# RFSO FLANGE	OUTLET
	1	A106	114 DIA. (4") SCH STD SMLS PIPE x 168 LG	
N5	1	A105	114 DIA. (4") 150# RFSO FLANGE	FILL
	1	A106	114 DIA. (4") SCH STD SMLS PIPE x 168 LG	
N6	1	A105	89 DIA. (3") 150# RFSO FLANGE	OVERFLOW
	1	A106	89 DIA. (3") SCH STD SMLS PIPE x 168 LG	
N7	1	A105	114 DIA. (4") 150# RFSO FLANGE	FILL
	1	A106	114 DIA. (4") SCH STD SMLS PIPE x 168 LG	

CUSTOMER:

400 BBL L-SKIDDED STORAGE TANK

TITLE:

QUOTE #:

NOZZLES			
MARK	PROJ.	ELEV.	NOTES
C1	MAX	927 mm	FUTURE LLSD
C2	MAX	5790mm	FUTURE HLSD
C3	MAX	1372mm	FUTURE TI
N1	152mm	ROOF	VENT
N2	100mm	115mm	DRAIN
N3	152mm	115mm	INLET
N4	152mm	115mm	OUTLET
N5	152mm	305mm	FILL
N6	152mm	6020 mm	OVERFLOW
N7	152mm	971mm	FILL

DESIGN NOTES	
1.	TANK TO BE BUILT AND TESTED TO API-12F SPEC. MODIFIED (NON-LABELLED)
2.	THIS TANK HAS NOT BEEN DESIGNED TO MEET THE EMERGENCY VENTING REQUIREMENTS OF API 2000 SPECIFICATION.
3.	ROOF/SHELL JOINTS NOT TO BE BACKWELDED
4.	ESTIMATED SHIPPING WEIGHT = 5,443 KG. (12,000#)
5.	REFER TO ORIENTATION DRAWING FOR PROPER LOCATION OF ALL NOZZLES, COUPLINGS, ETC.
6.	ALL DIMENSIONS ARE IN mm.
7.	NOZZLE ELEVATIONS TAKEN FROM TOP OF TANK FLOOR.
8.	ALL CONNECTIONS SHIPPED WITH PLUGS OR PVC FLANGE PROTECTORS UNLESS NOTED OTHERWISE.
THIRD PARTY INSPECTION	
TBD	
TESTING NOTES	
1. TANK IS TO BE AIR/SOAP LEAK TESTED TO 1.5 PSI	
WELDING NOTES	
1. E7024 WELDING ROD HAS NOT BEEN PROHIBITED.	

INTERNAL & EXTERNAL FINISH			
1. INTERNAL FINISH			
PREPARE WELDS FOR FUTURE INTERNAL COATING			
2. EXTERNAL FINISH			
BLAST:	SSPC-SP7 BRUSH BLAST USING SIL 7 SAND		
PRIMER:	1.5 - 2.0 MILS DFT OF CLOVERDALE TOWER OR RUSTEX #71024 GRAY		
PAINT:	1.5 - 2.0 MILS DFT OF CLOVERDALE ARGO GRAY CC425 MARINE ENAMEL		
3. BOTTOM FINISH			
BLAST:	SSPC-SP7 BRUSH BLAST		
PRIMER:	1.5 - 2.0 MILS DFT OF CLOVERDALE TOWER OR RUSTEX #71024 GRAY		
REVISIONS			
0	ISSUED FOR FABRICATION	RR	10.09.12
NO.	DESCRIPTION	BY	DATE

CUSTOMER:			
TITLE:			
64 CU. M. (400 BBL) 3658 x 6096 HIGH L-SKIDDED STORAGE TANK			
APPROVED BY:	CHECKED BY:	DRAWN BY:	RR
DATE:	08.16.12	TAG #:	-
SHEET:	1 OF 3	SCALE:	NTS
		DRAWING#:	B-17577-86
		SERIAL#:	17577-86
		REV.	0



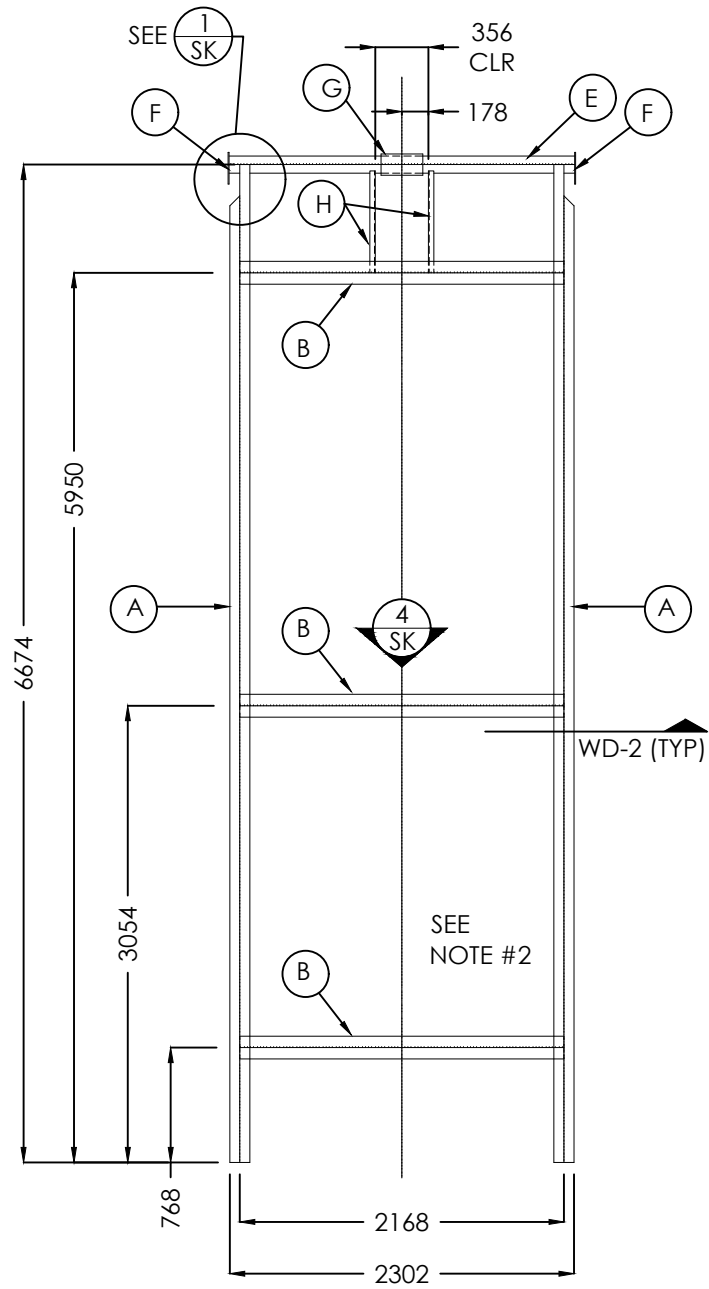

FRONT VIEW

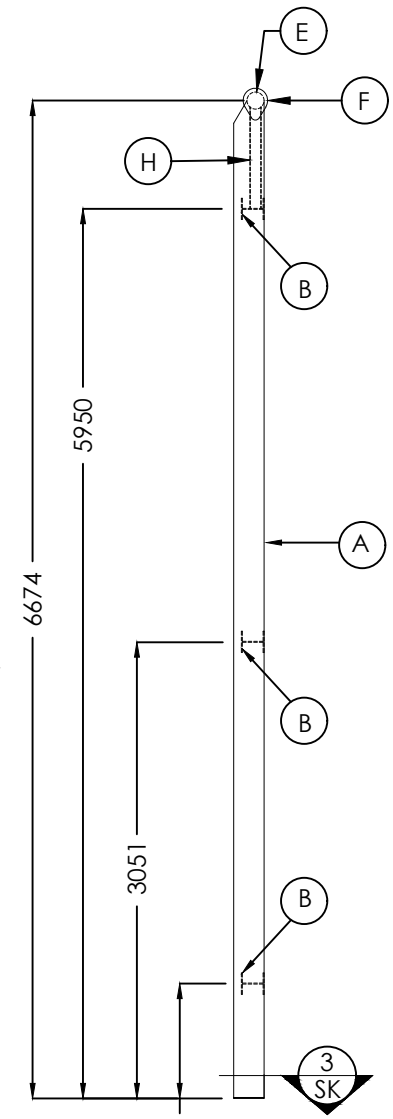

SIDE VIEW

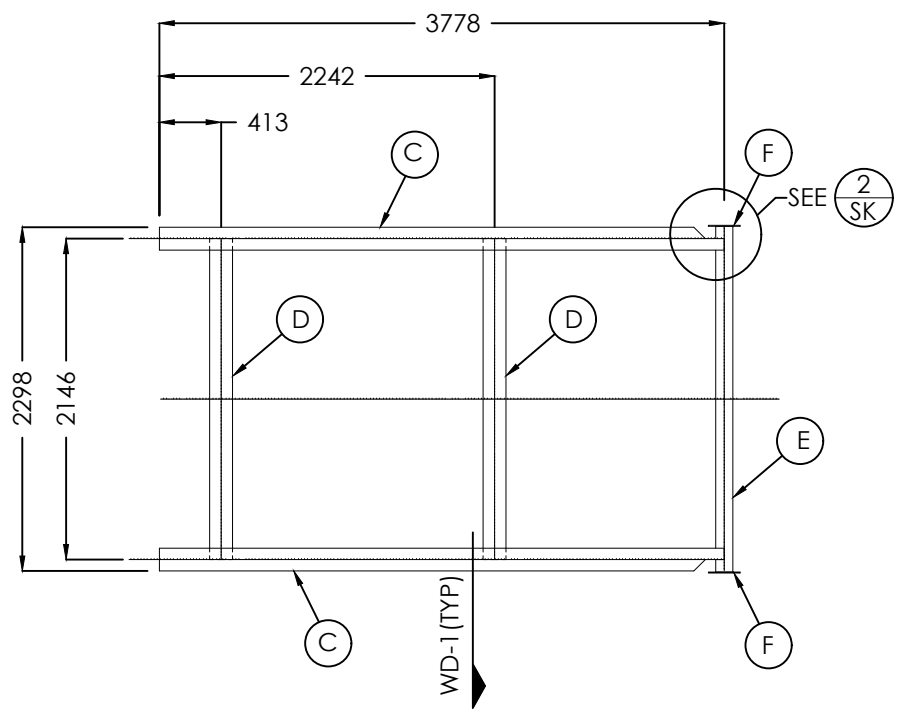

TOPVIEW

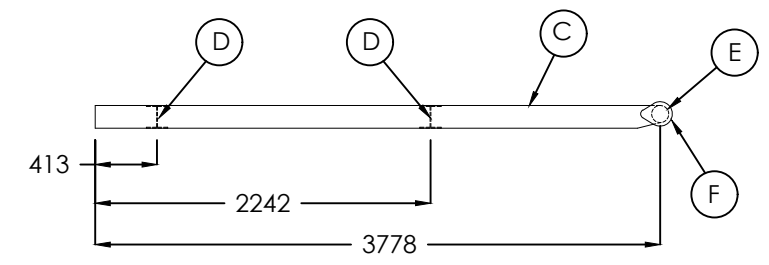

SIDE VIEW

400 BBL L-SKID BASE

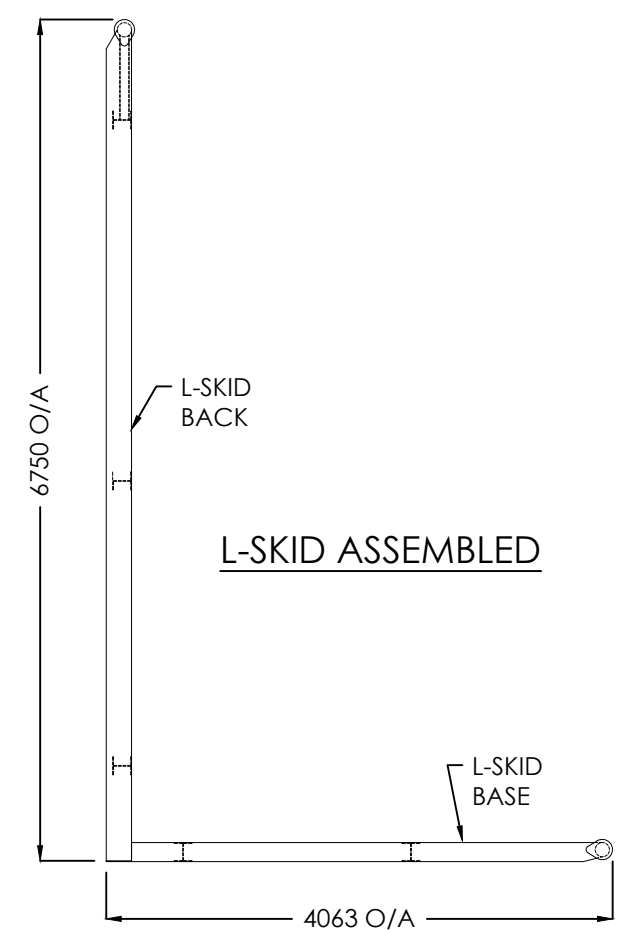

L-SKID ASSEMBLED

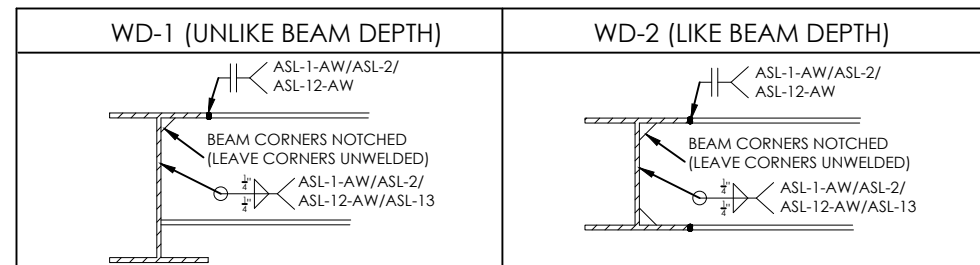

- WELD NOTES**
1. WELD ATTACHMENTS NOT DETAILED TO BE PERFORMED USING FILLET WELDS (SEAL WELD) USE APPLICABLE PROCEDURE FROM THOSE REFERENCES IN DETAILS ABOVE.
 2. FILLET WELD SIZES ARE DETERMINED BY THE SMALLEST THICKNESS OF THE TWO ITEMS TO BE JOINED UNLESS OTHERWISE NOTED.

BILL OF MATERIALS

MARK	QTY	MAT'L	DESCRIPTION	SERVICE
A	2	50W / A992	W200x27 (W8x18) WIDE FLANGE x 6674 LG	BACK SKID - RUNNERS
B	3	50W / A992	W150x22 (W6x15) WIDE FLANGE x 2162 LG	BACK SKID - CROSS PCS
C	2	50W / A992	W150x22 (W6x15) WIDE FLANGE x 3778 LG	BASE SKID - RUNNERS
D	2	50W / A992	W150x22 (W6x15) WIDE FLANGE x 2140 LG	BASE SKID - CROSS PCS
E	2	A53B	114 DIA. (4") SCH STD ERW PIPE X 2312 LG	ROLL ENDS
F	4	A36/44W	6.4 THK LARGE TEARDROPS	TEAR DROPS
G	1	A53B	140 DIA. (5") SCH. 40 ERW PIPE x 279 LG	SWIVEL SLEEVE
H	2	A36/44W	C75X6 (C3X4.1) CHANNEL X 678 LG (SHOP TO CONFIRM)	SWIVEL STOPS
I	4	A36/44W	6.4 THK X 51 FLAT BAR X 188 LG	STIFFENERS

SKID FINISH

BLAST: SSPC-SP7 BRUSH BLAST USING SIL 7 SAND
 PRIMER: 1.5-2.0 MILS DFT OF CLOVERDALE TOWER OR RUSTEX # 71024 (GRAY)
 PAINT: 1.5-2.0 MILS DFT OF CLOVERDALE MARINE ENAMEL

DESIGN NOTES

- 1) ALL DIMENSIONS ARE IN mm.
- 2) APPROXIMATE WEIGHTS:
 BASE SKID = 331 KG (720#)
 BACK SKID = 612 KG (1350#)
- 3) TORCH CUT DRAIN HOLES IN ITEM 'B' (SEE DETAIL THIS SHEET)

REVISIONS

NO.	DESCRIPTION	BY	DATE
0	ISSUED FOR FABRICATION	RR	10.09.12

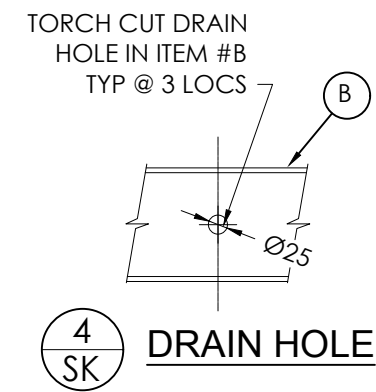
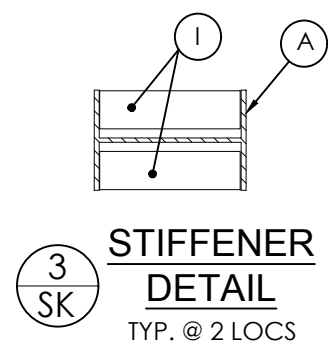
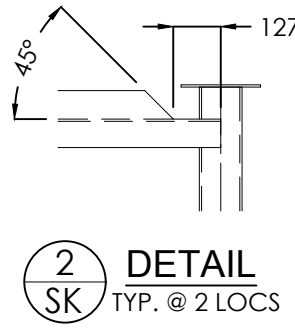
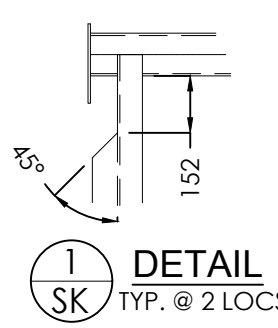

TORCH CUT DRAIN HOLE IN ITEM #B TYP @ 3 LOCS

CUSTOMER: ARGO SALES STOCK

TITLE: 400 BBL L-SKID

APPROVED BY:	CHECKED BY:	DRAWN BY:	RR
DATE: 08.16.12	TAG #:	DRAWING#: B-17577-86_LD	REV. 0
SHEET: 3 OF 3	SCALE: NTS	SERIAL#: 17577-86	QUOTE #:

ARGO SALES STOCK

CUSTOMER:

400 BBL SW L-SKID

TITLE:

QUOTE #: