

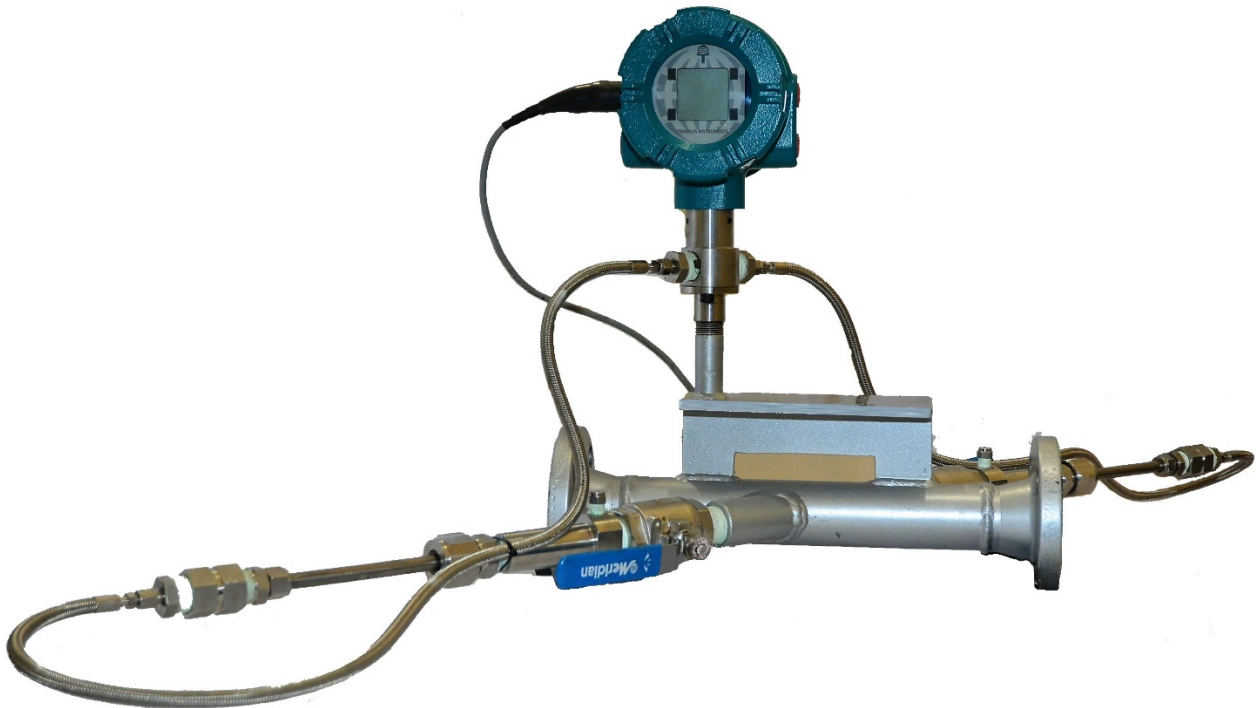

PROCON SYSTEMS (2013) INC.



Signature LPGX1 Series installation, operating & maintenance manual

DOCUMENT LPGX1 FLARE METER INSTRUCTION MANUAL	REVISION 1.5	REVISION DATE 12-NOV-2019	PAGE 1 OF 33
--	-----------------	------------------------------	-----------------

LPGX FLARE METER INSTALLATION, OPERATING AND MAINTENANCE MANUAL 01-09-2020



PROCON SYSTEMS (2013) INC.

Table of contents

1	Contents of this manual	5
1.1	Conventions	5
1.2	Abbreviations	6
2	Important information	7
2.1	Main hazards	7
2.2	Intended use	7
2.3	Identification	7
2.4	Operation in explosive atmospheres	7
2.5	Restrictions for use	7
2.6	Cleaning.....	7
2.7	User responsibility.....	7
2.8	Additional documentation	7
3	UIM Series Product description	9
3.1	Principle of operation.....	9
3.2	System components.....	10
3.2.1	Signal Processing Unit	10
3.2.2	Flowbody	10
3.2.3	Nameplate.....	11
3.2.3.1	Flowbody nameplate.....	11
3.2.3.2	SPU nameplate	11
3.3	Interfaces	12
3.3.1	Ground screw	12
3.3.2	Main board - Power supply.....	12
3.3.3	Main board - Frequency out	13
3.3.4	SLOT 1 - RS485 Option board terminals (01-0020 / TIP007)	13
3.3.5	SLOT 1 - RS485 IO 4..20mA Option board terminals (01-0202 / TIP010)	13
3.3.6	SLOT 2 - P/T Option Board (01-0022 / TIP008).....	14
3.3.7	SLOT 2 - 4..20mA Option board (01-0203 / TIP011).....	14
3.4	Front interfaces.....	15
3.5	Display and keypad	15
3.6	LEDs.....	15
3.7	USB Service interface and lock switch.....	15
4	Installation	16
4.1	Introduction	16
4.2	Installation in the pipeline	16
4.2.1	Installation configurations	16
4.3	Wiring of the LPGX1 Series.....	17
4.3.1	Determining installed option boards	17
4.3.2	Main board terminals.....	17
4.3.3	Slot 1, RS485 Option board terminals (01-0020)	18
4.3.4	Slot 1 RS485 IO 4..20mA Option board terminals (01-0202)	18
4.3.5	Slot 2 P/T Option board terminals (01-0022).....	18
4.3.6	Slot 2 4..20mA (HART) option board (01-0203)	19
4.3.7	Galvanic isolation	19
5	Start-up and commissioning.....	20
5.1.1	Powering up	20
5.1.2	Connecting to the USB Service port.....	20
5.1.3	Connecting to a flowcomputer or external device on the RS485 port	20

DOCUMENT LPGX1 FLARE METER INSTRUCTION MANUAL	REVISION 1.0	REVISION DATE 2-JAN-2020	PAGE 2 OF 33
--	-----------------	-----------------------------	-----------------



PROCON SYSTEMS (2013) INC.

5.1.4	Commissioning.....	21
6	Operation of the local user interface.....	22
6.1	LED indicators.....	22
6.2	Keypad.....	22
6.3	Normal operating mode screens.....	23
6.3.1	Contrast Control.....	24
6.4	Main Menu.....	24
6.4.1	System Info.....	25
6.4.2	Display Test.....	25
6.4.3	Diagnostic Display.....	25
6.4.4	USB Service mode.....	26
6.4.5	Clearing errors.....	26
7	Maintenance.....	28
7.1	Inspection of measurement and diagnostic data.....	28
8	Shipping & Storage.....	30
9	Spare parts and accessories.....	31
Appendix:		
A:	Diagnostic Codes.....	32
B:	Field Wiring Diagram C001756.....	33

DOCUMENT LPGX1 FLARE METER INSTRUCTION MANUAL	REVISION 1.0	REVISION DATE 2-JAN-2020	PAGE 3 OF 33
--	-----------------	-----------------------------	-----------------



PROCON SYSTEMS (2013) INC.

Introduction

This manual provides information about the installation, operation and maintenance of the Psignature series LPGX1 ultrasonic flare gas flowmeter. It contains information for correct operation and maintenance of this product. It also contains important instructions to prevent accidents and serious damage before commissioning and during operation. Furthermore the information provided ensures trouble free and safe operation of the equipment. Before operating the product read and understand this manual. Strictly follow the safety instructions and warnings.

In the event of questions or need for additional information regarding specific matters about the LPGX1 Flare Meter, please contact Procon Systems (2013) Inc. via email or telephone.

This instruction manual is based on the latest information at the time of writing. It is provided subject to changes and updates. We reserve the right to change the configuration and/or construction of our products at any time without obligation to update previously shipped products.

The warranty provisions stipulated in our Terms and conditions are applicable to the product. Procon Systems (2013) Inc. shall have no obligation in the event that:

- Repair or replacement of equipment or parts has been required through normal wear and tear, or due to negligence of the purchaser;
- The equipment, or parts, have been maintained or repaired by other than an authorized representative of Procon, or have been modified in any manner without prior express written permission of the manufacturer;
- Non-original parts are used;
- Equipment is used improperly, incorrectly, carelessly or not in line with its nature and/or purpose;
- Use of this product with unauthorized equipment or peripherals, including, but not necessarily limited to, cables, testing equipment, computers, voltage, etc.

Procon Systems (2013) Inc. is not responsible for the incidental or consequential damages resulting from the breach of any express or implied warranties, including damage to property, and to the extent permitted by law, damage for personal injury.

DOCUMENT LPGX1 FLARE METER INSTRUCTION MANUAL	REVISION 1.0	REVISION DATE 2-JAN-2020	PAGE 4 OF 33
--	-----------------	-----------------------------	-----------------



PROCON SYSTEMS (2013) INC.

1 Contents of this manual

This manual contains several sections, covering various aspects of the UIM series flowmeter.

Chapter 1	This chapter
Chapter 2	Important instructions
Chapter 3	UIM Series product description
Chapter 4	Installation
Chapter 5	Startup and commissioning
Chapter 6	Operation
Chapter 7	Maintenance
Chapter 8	Sealing
Chapter 9	Shipping
Chapter 10	Accessories and spare parts
Appendices	

1.1 Conventions

The following symbol and indication conventions are used throughout this manual.



Warning!

A warning indicates hazards or unsafe practices that could result in severe personal injury or death.



Attention!

This sign indicates potential hazardous or unsafe operations that could result in minor personal injury or damage of product or property. It is also used to indicate operations or practices that could cause the product to operate in an unexpected way or provide results outside its specification.

DOCUMENT LPGX1 FLARE METER INSTRUCTION MANUAL	REVISION 1.0	REVISION DATE 2-JAN-2020	PAGE 5 OF 33
--	-----------------	-----------------------------	-----------------



PROCON SYSTEMS (2013) INC.

1.2 Abbreviations

The following abbreviations are used throughout the document:

ATEX	ATmosphère EXplosible (European hazardous location standard)
CSA	Canadian Standards Association
EMC	Electromagnetic Compatibility
FM	Factory Mutual
IEC	International Electrotechnical Commission
IECEX	International Electro technical Commission certification scheme for Explosive atmospheres
IS	Intrinsic Safety
ISO	International Organization for Standardization
LCD	Liquid Crystal Display
LVD	Low Voltage Directive
OIML	Organisation Internationale de Métrologie Légale
PCBA	Printed Circuit Board Assembly
PED	Pressure Equipment Directive
SPU	Signal Processing Unit
USM	Ultrasonic Flowmeter

2 Important information

2.1 Main hazards

	<p>Warning!</p> <p>Pressurized flammable gas flows through the Flowbody of the UIM series ultrasonic gas flowmeter. Do not remove any transducers or parts from the flowbody whilst the flowmeter is under pressure. Flammable gas can escape and parts may blow out.</p>
---	--

2.2 Intended use

The LPGX1 series ultrasonic gas flare flowmeter is primarily used to measure the volumetric and mass flow rate as well as gas velocity of flare and vent gases.

Optionally the LPGX1 series can convert the volume flow at measuring conditions to base conditions as well as providing data on meter readings, diagnostics and other data.

2.3 Identification

Each LPGX1 Series flowmeter has two nameplates for identification, one on the SPU and one on the flowbody. Refer to chapter 3.2.3 for detailed information about the nameplates and identification.

2.4 Operation in explosive atmospheres

The LPGX1 series is intrinsically safe and suitable for use in potentially explosive atmospheres. Refer to the Safety instructions [1] (TI2_UIM_GEN7_Safety_instructions) for detailed information about this.

- ATEX Ex ia IIC T4 Gb
- IECEX Ex ia IIC T4 Gb
- US / Canada Ex ia IIC T4 Gb

2.5 Restrictions for use

The LPGX1 series flowmeters are suitable for use in pressurized lines within the design conditions specified on the flowmeter nameplate.

2.6 Cleaning

Only clean the LPGX1 series ultrasonic flowmeter with a damp cloth. Do not use solvents for cleaning.

2.7 User responsibility

The user should read and understand the operating instructions prior to putting the LPGX1 ultrasonic flaremeter in use. All safety information should be observed. In case of doubt always contact Procon Systems (2013) Inc.

2.8 Additional documentation

Additional documentation is delivered with the product. This contains specific set-up data for the individual flowmeter. Depending on the configuration the following documentation is delivered with the meter.

- Certificate of conformity / EX certificates
- Safety instructions

DOCUMENT LPGX1 FLARE METER INSTRUCTION MANUAL	REVISION 1.0	REVISION DATE 2-JAN-2020	PAGE 7 OF 33
--	-----------------	-----------------------------	-----------------



PROCON SYSTEMS (2013) INC.

- Material certificates
- Inspection certificate
 - Meter configuration sheet
 - Factory acceptance test report

Furthermore, product information such as this manual can be downloaded from the website

DOCUMENT LPGX1 FLARE METER INSTRUCTION MANUAL	REVISION 1.0	REVISION DATE 2-JAN-2020	PAGE 8 OF 33
--	-----------------	-----------------------------	-----------------

3 LPGX1 Series Product description

3.1 Principle of operation

The LPGX1 Series ultrasonic flare gas flowmeter uses the transit time differential measurement technique.

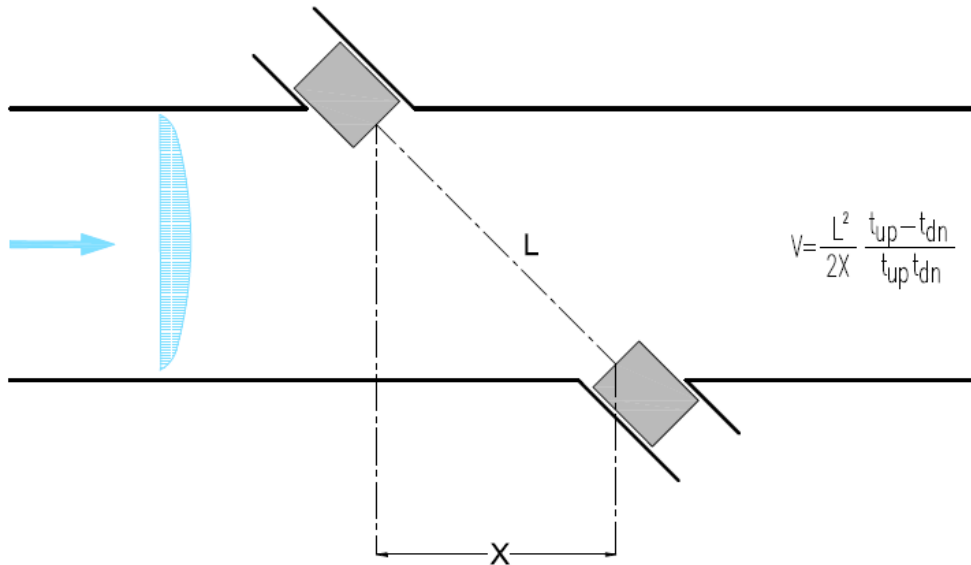

Figure 3-1 - principle of operation

Measured ultrasonic signal transit times t_{up} and t_{dn} are defined by the sound and gas velocity. Gas velocity V is proportional to the difference between the signal transit times. Changes in the sound velocity caused by pressure or temperature fluctuations do not affect the calculated gas velocity with this measurement method. The LPGX1 series ultrasonic gas flowmeter calculates the volumetric flow rate based on the gas velocity and the Flowbody internal diameter.

3.2 System components

The LPGX1 series comprises of a Signal Processing Unit (SPU), Flowbody with transducers, nameplate with other essential information.

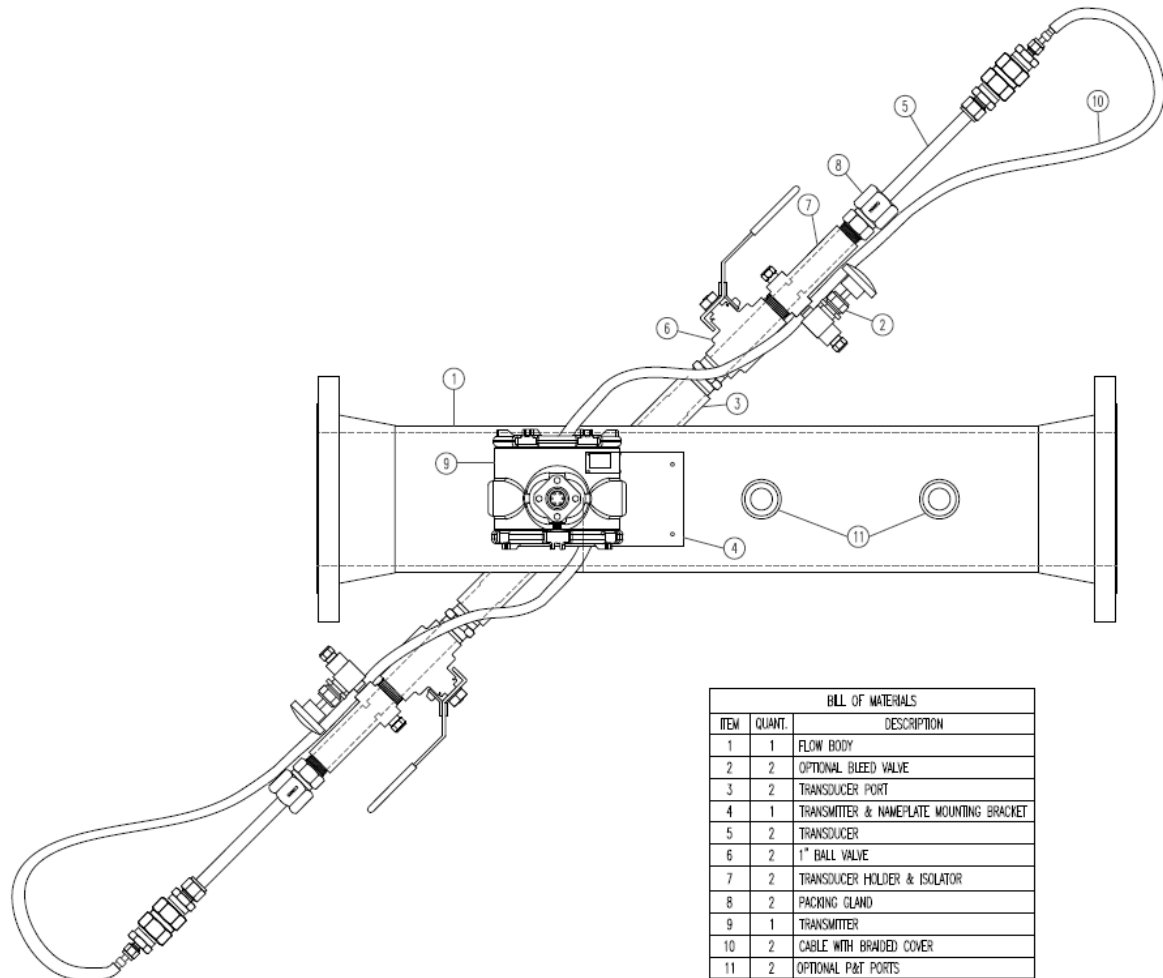

Figure 3-2 - System components

3.2.1 Signal Processing Unit

The Signal Processing Unit (SPU) consists of a mainboard that contains all the electronic circuits for operation of the unit. In addition to the mainboard two additional boards can be placed for extra functionality such as pressure and temperature sensor interfaces and additional Input/Output interfaces.

The mainboard interfaces to the transducers and controls the complete measuring process. All interfaces except the USB service port are intrinsically safe.

3.2.2 Flowbody

The Flowbody is used to install the LPGX1 series flaremeter in the flare or vent piping. It is available in various pipe sizes, materials, pressure ratings and flange types.



PROCON SYSTEMS (2013) INC.

3.2.3 Nameplate

Nameplates and labels are fitted on the LPGX1 Series flaremeter for identification and to provide details on the specific product as well as safety related information. Together with the safety instructions and this manual it specifies how to use the product and how it is designed and certified.

The main nameplate is fitted on the Flowbody and provides information on mechanical design conditions as well as flow related information such as meter factor and range. The meter's serial number is also provided on this nameplate.

The nameplate on the SPU provides the relevant electrical and hazardous area approval details according to ATEX, IECEx, FM or CSA. The electronics individual serial number is provided on this nameplate. Refer to the Safety instructions for an example of this nameplate.

3.2.3.1 Flowbody nameplate

The Flowbody nameplate includes the following information:

- Tag number
- Purchase order number
- Drawing number
- Design Pressure (kPag)
- Design Temperature (°C)
- Hydro Test Pressure (kPag)
- M.D.M.T. (°C)
- CRN #
- Nominal O.D. (mm)
- Measured I.D. (mm)
- Wall Thickness (mm)
- Chan 1 Path Dimension (mm)
- Chan 1 Axial Dimension (mm)
- Chan 2 Path Dimension (mm) – *if installed*
- Chan 2 Axial Dimension (mm) – *if installed*
- Procon Master #
- Year Manufactured
- Flow Direction

3.2.3.2 SPU nameplate

The SPU nameplate includes the following information:

- Company name and address
- Type of Ultrasonic flowmeter Electronics
- Hazardous area approval
- Model identification
- Serial number of the SPU
- Power requirements of the SPU
- Year of manufacture
- Substitution of components may impair intrinsic safety

DOCUMENT LPGX1 FLARE METER INSTRUCTION MANUAL	REVISION 1.0	REVISION DATE 2-JAN-2020	PAGE 11 OF 33
--	-----------------	-----------------------------	------------------

3.3 Interfaces

The LPGX1 series flaremeter has several electrical interfaces. This chapter describes their function, operating parameters and intrinsic safety relevant information.

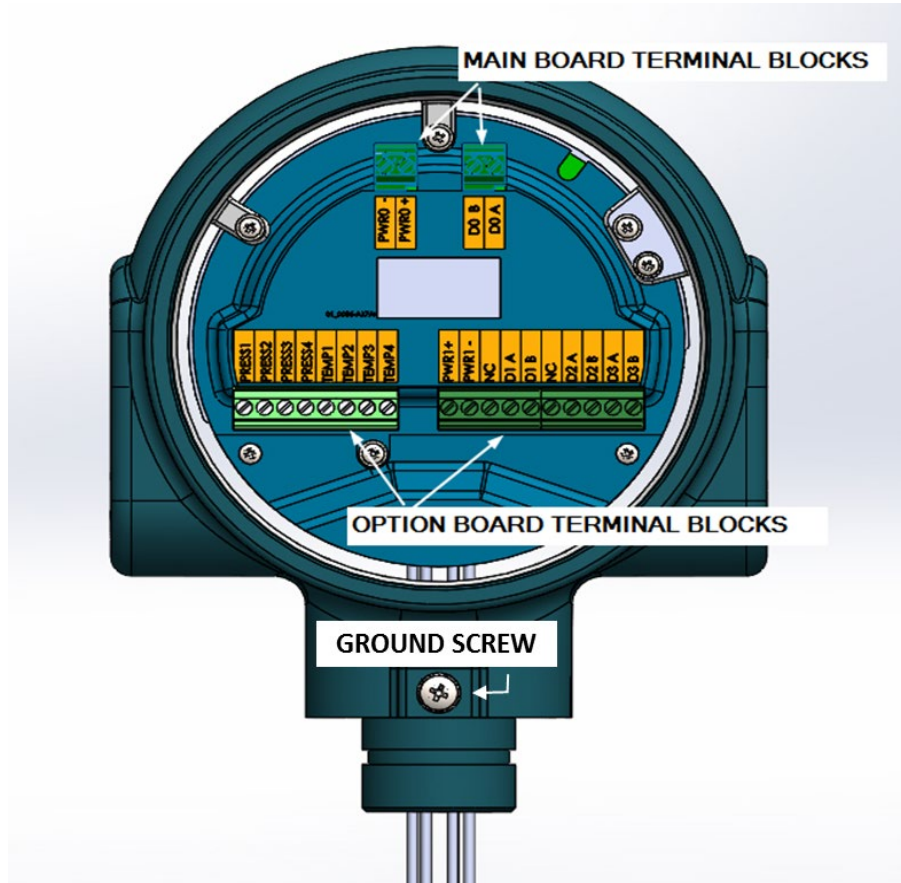

Figure 3-3 - UIM SPU electrical interfaces shown with RS485 and PT option board

3.3.1 Ground screw

A ground screw is provided to connect the UIM SPU to ground / earth.

3.3.2 Main board - Power supply

The UIM SPU requires an external intrinsically safe power supply.

Signal	Function
PWR -	Power supply
PWR +	



Warning!

The power supply interfaces of the UIM SPU are reverse polarity protected up to 250mA max. Always connect via a suited intrinsically safe isolator or barrier.
Refer to Control drawing 01-0198 for detailed information



PROCON SYSTEMS (2013) INC.

3.3.3 Main board - Frequency out

A frequency out / pulse output is available on the mainboard (base configuration), the main purpose of this output is to provide pulses proportional to the volume flowing through the pipeline. The number of pulses per unit volume (m3 or cubic feet) is printed on the nameplate.

Signal	Function
D0_B	Frequency output -
D0_A	Frequency output +

3.3.4 SLOT 1 - RS485 Option board terminals (01-0020 / TIP007)

Optionally the UIM SPU can be fitted with an I/O option board, extending the functionality of the system. The option board requires a separate intrinsically safe power supply.

Signal	Function
PWR1 +	Option board power supply
PWR1 -	Option board power supply
D1_B	RS485 B
D1_A	RS485 A
D2_B	Digital output -
D2_A	Digital output +
D3_B	Digital output -
D3_A	Digital output +

3.3.5 SLOT 1 - RS485 IO 4..20mA Option board terminals (01-0202 / TIP010)

When the UIM SPU is fitted with the RS485 IO 4..20mA option board, The option board requires a separate intrinsically safe power supply, The board's supply, at the same time will function as a 4..20mA output.

Signal	Function
PWR1 +	Option board power supply / 4..20mA loop
PWR1 -	Option board power supply / 4..20mA loop
D1_B	RS485 B
D1_A	RS485 A

PROCON SYSTEMS (2013) INC.

D2_B	Digital output -
D2_A	Digital output +
D3_B	Digital output -
D3_A	Digital output +

3.3.6 SLOT 2 - P/T Option Board (01-0022 / TIP008)

In addition, the UIM SPU can be fitted with an optional Pressure / temperature board, extending the functionality of the system with pressure and temperature measurement capabilities. This enables the LPGX1 Series flowmeter to calculate base volume using PTZ conversion. A pressure and temperature sensor are then supplied, and installed on the flowmeter by Procon Systems (2013) Inc.

3.3.7 SLOT 2 - 4..20mA Option board (01-0203 / TIP011)

When equipped with a this option board a passive (externally powered) mA output is available. The output is software configurable for any parameter required, however normally it is used for flowrate, gas velocity etc. Using the PC tool TIM, it can be configured and calibrated.

Signal	Function
LPWR1 +	4..20mA loop +
LPWR1 -	4..20mA loop -

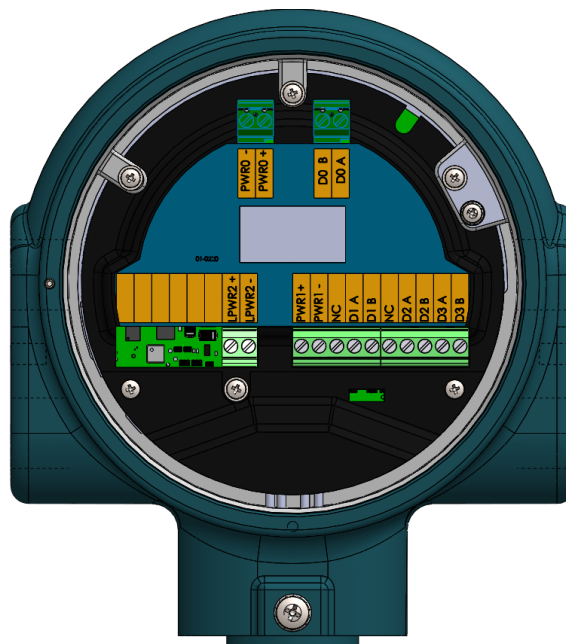

Figure 3-4 - display, keypad, USB and switch

3.4 Front interfaces

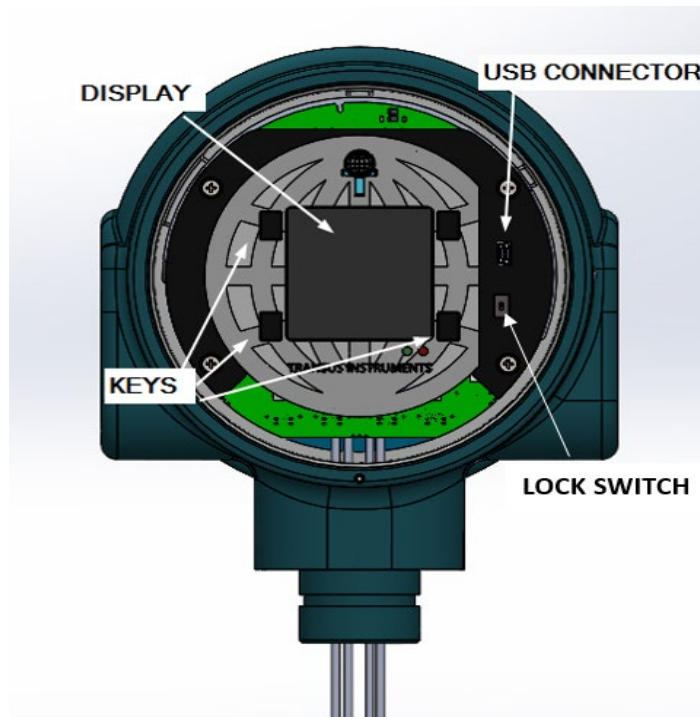

Figure 3-5 - display, keypad, USB and switch

3.5 Display and keypad

The front of the UIM SPU electronics is equipped with a graphical 128x128 dot matrix LCD graphic display. Four navigation keys are located at the corners of the display for operation of the local user interface.

3.6 LEDs

Two LED's are provided on the front panel. Their function is explained in detail in chapter 6.

- Green LED = Power indication
- Red LED = Status / Error indication

3.7 USB Service interface and lock switch

On the right side of the display a mini USB connector is present for connection of a laptop.



Attention!

This interface is not intrinsically safe and therefore powered by the USB host (laptop or computer). It may be used in a safe area only or after taking suitable precautions such as gas detection. Refer to the Safety instructions [1] for further details.

The parameter lock switch is located below the USB connector and provides a way to lock all relevant parameters. This switch can be protected with a tamper proof sticker. Refer to chapter 8 (Sealing) for more details on the lock switch.

Note: the sticker shall also cover one of the display bracket screws

4 Installation

4.1 Introduction

It is very important to check the shipment of your ultrasonic flow meter equipment. By means of a visual inspection of surfaces, paint, flange sealing faces and electronics housing should be performed. In case of damage, contact Procon Systems (2013) Inc. immediately.

In addition verify all the necessary documentation is available as well:

- Safety instructions [1]
- Installation, operation and Maintenance manual (this document)

In addition to this additional documentation may be required based on project specifications. In the event documentation is missing contact Procon Systems (2013) Inc. or your local representative immediately.

4.2 Installation in the pipeline

Install the LPGX1 flare meter according to end-user's company regulations and applicable local and national requirements. To ensure optimal performance of the flowmeter, comply with the up- and downstream spool requirements specified for your particular application.



Warning!

To avoid possible strain, ensure your lifting equipment is suitable for the weight of the LPGX1 series flowmeter. Make sure to use approved lifting equipment and the equipment shows no damage or wear.

4.2.1 Installation configurations

The recommended installation configurations are shown in Figure 4-1 below.

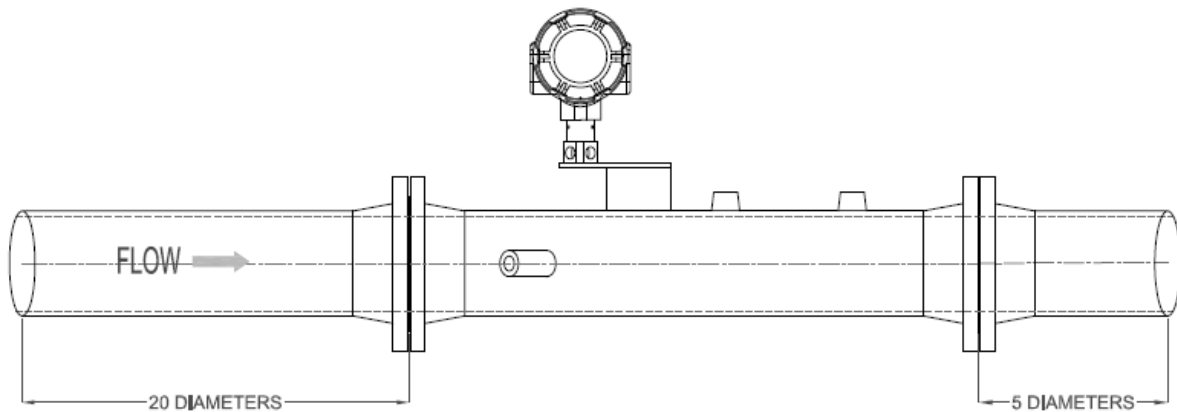

Figure 4-1 – Recommended Installation configuration



Attention!

The LPGX1 Series Flaremeter should be installed in the horizontal plane with the transducer ports in the 3 & 9 o'clock position. This orientation allows the ports to self-drain if any liquids are present.

Always consult with Procon Systems (2013) Inc. concerning other possible installation requirements.

DOCUMENT LPGX1 FLARE METER INSTRUCTION MANUAL	REVISION 1.0	REVISION DATE 2-JAN-2020	PAGE 16 OF 33
--	-----------------	-----------------------------	------------------

4.3 Wiring of the UIM SPU Series

This chapter provides information for correct wiring of the UIM SPU electronics. The electronics enclosure is provided with up to four cable gland entries with metric (M20x1.5) or imperial (1/2" NPT) thread. Suitable shielded cables must be used (for signal and communication cables the use of twisted pair cables is recommended) whereby the cables are protected from mechanical damaged as well as electrical interference. In addition, ensure length, diameter, core are suitable for the length required in the field. As a minimum 0.75mm² core cross sectional area should be used. All terminal connections use the Phoenix contact MK3DSH series terminal blocks, suitable for wires with a core cross sectional area up to 2.5 mm².





Attention!

For a reliable connection always use insulated wire end terminals compatible with the cable core cross sectional area.



Warning!

REFER TO CONTROL DRAWING 01-0198 FOR THE INTRINSIC SAFETY PARAMETERS.

4.3.1 Determining installed option boards

In order to determine which option boards are installed in your LPGX1 Series flowmeter, locate the UIM Electronics model number on the nameplate of the SPU. Using the table on the control drawing (drawing 01-0198) determine which option boards are installed.

4.3.2 Main board terminals

Signal	Function	Operating parameters
PWR -	Power supply	Rated input voltage 12..29VDC (After safety barrier)
PWR +		
D0_B	Frequency output -	0 .. 5kHz Passive open drain, not electrically isolated from system ground**
D0_A	Frequency output +	



Warning!

The power supply interfaces of the UIM SPU are reverse polarity protected up to 250mA max. Always connect via a suited intrinsically safe isolator or barrier.
Refer to Control drawing 01-0198 for detailed information



PROCON SYSTEMS (2013) INC.

4.3.3 Slot 1, RS485 Option board terminals (01-0020)

Signal	Function	Operating parameters
PWR1 +	Option board power supply	Power supply for the I/O option board (10-29VDC) (After safety barrier)
PWR1 -	Option board power supply	
D1_B	RS485 B	Differential RS485 two wire communications port, galvanically isolated
D1_A	RS485 A	
D2_B	Digital output -	Passive, optically isolated open collector
D2_A	Digital output +	
D3_B	Digital output -	Passive, optically isolated open collector
D3_A	Digital output +	

4.3.4 Slot 1 RS485 IO 4..20mA Option board terminals (01-0202)

Signal	Function	Operating parameters
PWR1 +	4..20mA Loop / power supply	Power supply for the I/O option board and the 4..20mA loop. (10-29VDC, After safety barrier)
PWR1 -	4..20mA Loop / Loop power supply	
D1_B	RS485 B	Differential RS485 two wire communications port, galvanically isolated
D1_A	RS485 A	
D2_B	Digital output -	Passive, optically isolated open collector
D2_A	Digital output +	
D3_B	Digital output -	Passive, optically isolated open collector
D3_A	Digital output +	

4.3.5 Slot 2 P/T Option board terminals (01-0022)

Signal	Function	Operating parameters
PRESS1	Bridge +	Connections to the resistive bridge type pressure sensor (factory default = voltage mode sensor). Refer to Safety instructions for approved pressure sensors. Or contact Procon Systems (2013) Inc. for more information
PRESS2	Signal +	
PRESS3	Signal -	
PRESS4	Bridge -	
TEMP1	Supply +	Connections to the RTD sensor (factory default = 4 wire PT100). Refer to Safety instructions for approved pressure
TEMP2	Signal +	

DOCUMENT LPGX1 FLARE METER INSTRUCTION MANUAL	REVISION 1.0	REVISION DATE 2-JAN-2020	PAGE 18 OF 33
--	-----------------	-----------------------------	------------------



PROCON SYSTEMS (2013) INC.

TEMP3	Signal -	sensors. Or contact Procon Systems (2013) Inc. for more information
TEMP4	Supply -	

4.3.6 Slot 2 4..20mA (HART) option board (01-0203)

Signal	Function	Operating parameters
LPWR2+	Loop power supply	
LPWR2-	Loop power supply	

4.3.7 Galvanic isolation

In case galvanic isolation is required the use of an external isolator on frequency output D0 is required.

5 Start-up and commissioning

5.1.1 Powering up

After the SPU has been wired and powered up it is advisable to read out a complete list of parameters. In case of a flow calibrated meter, it is recommended to verify the parameters as found with the calibration parameters.

The parameters can be read with the “TIM” software tool (consult Procons Systems (2013) Inc. to obtain tool). A serial connection can be made via the USB interface.



Warning!

When connecting a PC or laptop in the hazardous area, ensure the rules and regulations to work with non EX equipment are met.

A flow calibrated meter should have the parameter lock switch closed and tamper proof sealing sticker in place. Make sure this is in place. Refer to chapter 8 for more details about sealing.

5.1.2 Connecting to the USB Service port

To connect to the UIM SPU via the USB Service port it may be necessary to put the UIM SPU in USB Service mode. When the communication mode is set to the RS485 port, the USB Service mode enables to temporarily interface via the USB port. Refer to chapter 6.4 for details how to enable the USB service mode.



Attention!

When USB Service mode is enabled it will temporarily disable the RS485 option board.

When there is no activity for 60 seconds on the USB port the UIM SPU resumes normal operation again.

The default USB communication port settings are

Baudrate	115400
Parity	None
Databits	8
Stopbits	1
Modbus address	1

Table 1 – USB port default communication settings

5.1.3 Connecting to a flow computer or external device on the RS485 port

When fitted with an option board for RS485 communications the UIM SPU can be connected to a flow computer or external device using the MODBUS RTU protocol.

The default communication protocol and serial port settings are provided in the table below.

DOCUMENT LPGX1 FLARE METER INSTRUCTION MANUAL	REVISION 1.0	REVISION DATE 2-JAN-2020	PAGE 20 OF 33
--	-----------------	-----------------------------	------------------

Baudrate	38400
Parity	None
Databits	8
Stopbits	1
Modbus address	1

Table 2 – RS485 port default communication settings

The Modbus address map can be provided on request.

The UIM SPU has a built in 120 ohm termination resistor in case the RS485 network needs to be terminated at this position. The switch shown in Figure 5-1 can be used for this

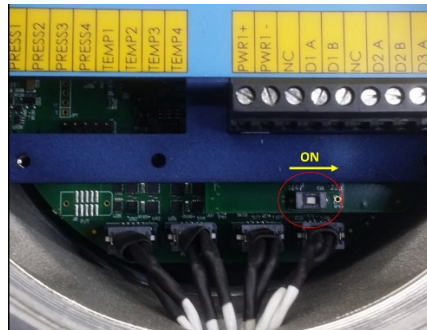

Figure 5-1 - Line termination resistor switch

5.1.4 Commissioning

When possible verify operation of the flowmeter at (near) zero flow at known gas composition. Zero flow readings and diagnostics should be recorded and assessed. After this zero flow check, start the gas flow and monitor readings and diagnostics for proper operation of the device. Ensure that the frequency signal provided by the meter matches the volume flow reading on the local LCD.

It is recommended to log meter readings and diagnostics using the “TIM” software tool during startup conditions.

6 Operation of the local user interface

In this chapter the operation via the local user interface is explained.

6.1 LED indicators

The UIM SPU has two LED indicators, located underneath the LC Display, their function is described in following tables.

- Power LED - GREEN

LED status	Interval	Description
Off	--	Power off
Green, flashing	2 Sec	Power on, system running

- Status LED - RED

LED status	Interval	Description
Off	--	Status OK
Red, flashing	1 Sec	Warning
Red, flashing	0.5 Sec	Error
Red, flashing	2 Sec	Status OK, unacknowledged transient Error present



Figure 6-1 - LCD and keypad (front cover removed)

6.2 Keypad

The keypad has four function keys which correspond with a function shown in the corners of the LCD. Each key will have a function depending on the operating mode of the interface.

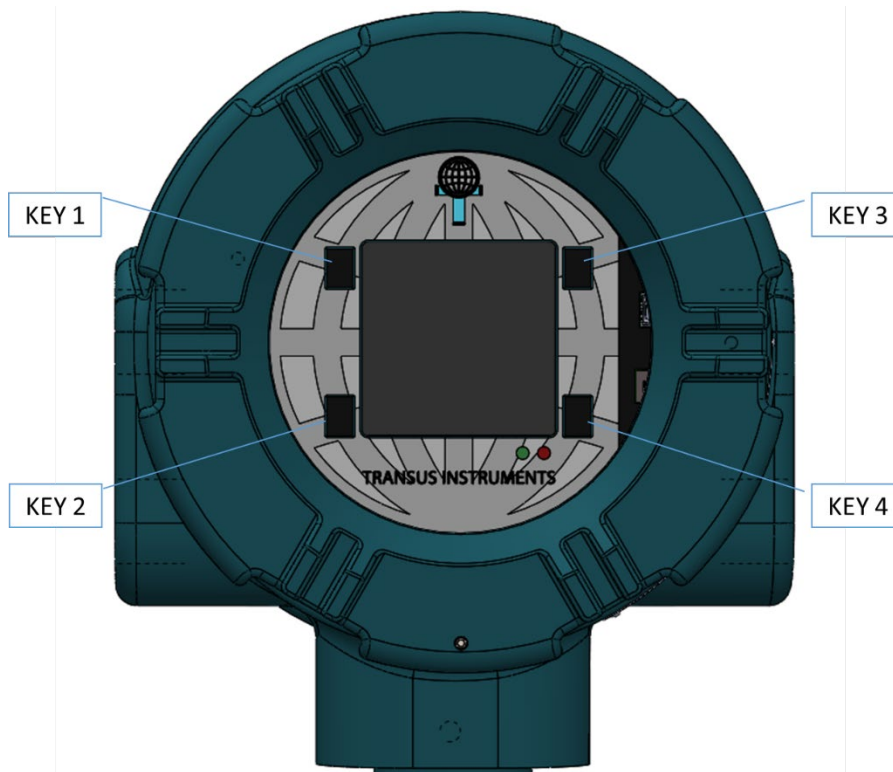
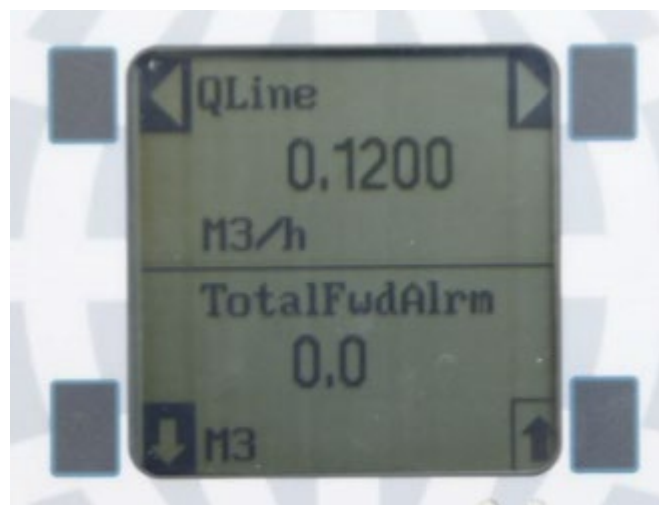

Figure 6-2 - Front view of keypad and display

6.3 Normal operating mode screens

During normal operation the UIM SPU provide the essential information on areas on the LCD. The following parameters can be displayed on both the upper and lower section of the LCD. Using the keys on the keypad different parameters can be selected.





PROCON SYSTEMS (2013) INC.

The upper display is “static” - that is only the selected parameter is displayed. The parameter may be changed manually using the ◀ <left> and ▶ <right> scroll keys.

The lower display will automatically scroll through the remaining parameters. The full list of parameters is shown below.

The following parameters can be viewed.

- Totalized volume forward (TotalFwd)
- Totalized volume reverse (TotalRev)
- Totalized volume forward in alarm conditions (TotalFwdAlrm)
- Totalized volume reverse in alarm conditions (TotalRevAlrm)
- Volumetric flowrate (Qline)
- Velocity of Gas (VoGCor)
- Velocity of Sound (VoSAvg)
- Meter status (MeasStatus). For a list of status codes refer to Appendix A.

6.3.1 Contrast Control

The bottom two keys are used for contrast control. Use the ⬇ <-contrast> and ⬆ <+contrast> keys to adjust the contrast of the LCD.

6.4 Main Menu

Pressing the upper left key while in normal operating mode for 3 to 5 seconds will bring up the main menu of the UIM SPU.

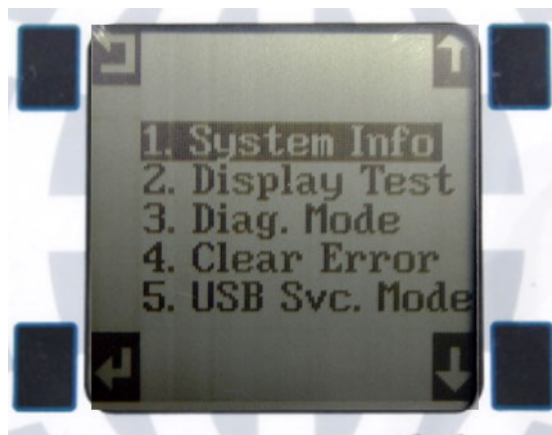

The four function keys have now changed into ⬆ <up>, ⬇ <down>, ↵ Escape <ESC> and ↵ Enter <ENT>. Using the up and down arrow keys a menu option can be selected, pressing <ENT> will show the highlighted menu or function. To go back one step, press <ESC>.

The following menu options are available

1. System Info
2. Display Test
3. Diagnostic Menus

DOCUMENT LPGX1 FLARE METER INSTRUCTION MANUAL	REVISION 1.0	REVISION DATE 2-JAN-2020	PAGE 24 OF 33
--	-----------------	-----------------------------	------------------



4. Clear error
5. USB Service mode (unavailable in “console” mode)

6.4.1 System Info

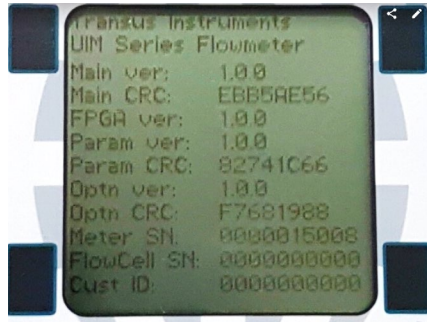
The System Info Menu provides information about the UIM SPU software and hardware. After a few seconds the display will exit to the Operating Mode



6.4.2 Display Test

When **Display Test** is highlighted and selected using the  <down>, and then  <ENT> a pattern will be scanned across the display to test all pixels. After the test the display will revert to the Operation Mode.

6.4.3 Diagnostic Display

When **Diagnostic Display** is highlighted and selected the following screen will be displayed

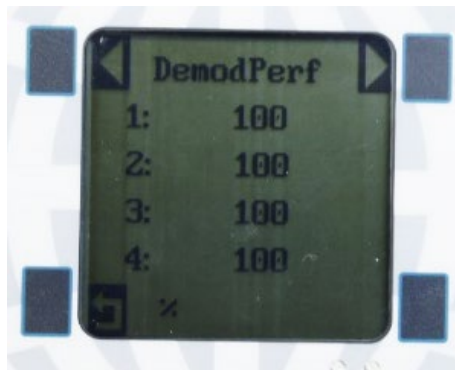

This screen shows diagnostic information for all enabled paths. Only those active paths will display data.

Scroll to the next diagnostic value using the  <right> scroll key.

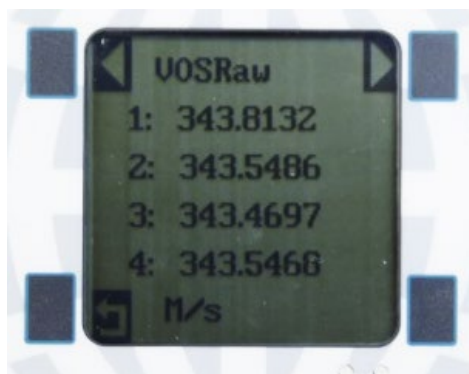

The following diagnostic values may be displayed using the ◀ <left> and ▶ <right> scroll keys:

- Performance (DemodPerf)
- Velocity of Sound (VOSRaw)
- Gas Velocity (VoG)
- Gain AB (AGC AB)
- Gain BA (AGC BA)
- Signal to noise ratio AB (SNR AB)
- Signal to noise ratio AB (SNR BA)
- Path Status AB (Status AB)
- Path Status BA (Status BA)

The diagnostic values and interpretation is discussed further in section 7: *Maintenance*.

Pressing ◀ <ESC> will return to the normal operating display.

6.4.4 USB Service mode

When **USB Serv. Mode** is highlighted and selected using the ↓ <down>, and then ◀ <ENT> the UIM SPU will enter the USB service mode, enabling communications via the USB port. A message “USB Service Mode” will be shown on the display.

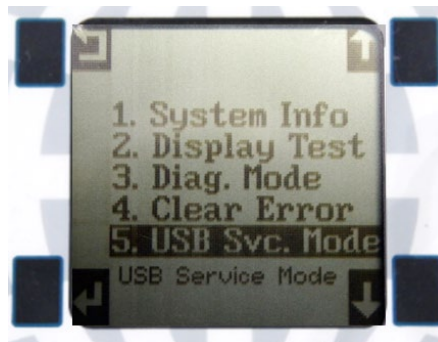

When pressing ◀ <ENT> again the UIM SPU will revert to the normal operation mode.

“TIM” software can be used to communicate via the USB port when in USB service mode.

6.4.5 Clearing errors

In the event an alarm or warning condition is active, the diagnostic code (refer to appendix A) is shown on the lower part of the LCD display until it is acknowledged by the user. Acknowledging alarms or warnings can be done via the main menu option 4 – Clear Alarms. If the error condition is still active the alarm or warning cannot be cleared.

PROCON SYSTEMS (2013) INC.



Figure 6-3 Error code to be acknowledged by user



PROCON SYSTEMS (2013) INC.

7 Maintenance

The LPGX1 Series ultrasonic flowmeter contains no moving parts. The sensors and electronics are virtually maintenance free, however periodic inspection is recommended at regular intervals. By collecting a short log file of measurement and diagnostic data at known and repeatable conditions the meter’s health status can be observed.

7.1 Inspection of measurement and diagnostic data

By comparing diagnostic data with previously collected data a good indication of the flowmeter’s condition can be observed. Below chapters outline the most significant diagnostic indicators. The display of diagnostic data is described in section 6.4.3 or may downloaded from the USB port or RS485 optional I/O port using a Modbus protocol. For the Modbus map or the “TIM” PC tool to download diagnostic and flow information contact Procon Systems (2013) Inc.

- **Performance**

This diagnostic indicates the percentage of accepted ultrasonic signals per path. The lower limit is set to 20% by default. At high flows or very turbulent flows, some rejection of ultrasonic signals may occur. The performance indicator is available for each activated path.

- **Velocity of Sound (VoS)**

The LPGX1 series flowmeter calculates the average velocity of sound (VoS) based on the individual activated measuring paths. The average VoS is simply the average of the paths installed and activated on the meter. Individual VoS for each path is also provided. Under normal conditions the individual path velocities should be reading very close. When possible the theoretical velocity of sound using AGA-10 calculations based on temperature, pressure and gas composition may be compared to the measured average VoS.

- **Gas Velocity (VoG)**

When possible the meter can be isolated from flowing conditions (using block valves). In this condition the meter should read less than 0.01 m/s. this is however extremely difficult to check due to natural convection inside the pipe and Flowbody as a result of slight temperature differences, causing the gas to circulate in the blocked pipe section.

- **Gain (AGC AB and AGC BA)**

For each transducer the required gain in the receiver is controlled. Gain values should be in the normal operating range for all transducers. Gain values depend on gas pressure, composition and velocity, therefore gain values may differ between events.

Gain	Condition
>900	Very weak or no signal
100 - 900	Good
< 100	Very strong or saturated signal

- **Signal to noise ratio (SNR AB and SNR BA)**

The SNR is calculated in dB for each received signal transducer. SNR values depend on gas pressure, composition and velocity. Below table provide information on Signal to noise ratio conditions.

SNR	Condition
>50	Very good
20 - 50	Good
10 - 20	Poor – fair
<10	Bad



PROCON SYSTEMS (2013) INC.

- **Path Status (PathStatus AB and PathStatus BA)**

The Path Status diagnostic values provide a more detailed indication of the health of each activated and installed path in each direction of transmission using an 8 digit number. A zero value (0x00000000) indicates that all parameters are within limits and no errors are present. The error codes are tabulated in Appendix A.

DOCUMENT LPGX1 FLARE METER INSTRUCTION MANUAL	REVISION 1.0	REVISION DATE 2-JAN-2020	PAGE 29 OF 33
--	-----------------	-----------------------------	------------------

8 Shipping & Storage

Use suitable means for transportation, loading and unloading of the LPGX1 Series flow meter. Pay particular attention to the transducer tubes to ensure they are not damaged or bent.

Once the flowmeter has been removed from its packaging, lifting and moving may only be carried out using suitable, properly fitted lifting equipment.

Take care that the meter will be installed on a vibration free location. Continuous vibration or shocks may have an adverse effect on the construction of the flow meter.

The dimensions and weight of the package depend on the type and size of the ultrasonic flare gas flow meter and are to be specified on the packing list.

If the LPGX1 Series flowmeter needs to be stored for a certain period of time before installation the following storage conditions do apply:

- It is recommended to use a corrosion preventative coating (oil, WD40, tectyl) on all bare metal parts of the flowcell (e.g. inside, flange surfaces,...),
- Be aware to remove the corrosion preventative coating prior to putting the flowmeter in service
- Storage temperature -30 °C to 60 °C
- Storage relative humidity 5 – 95% RH, non-condensing
- Use moisture absorbing bags (silica gel) inside the SPU to protect the electronics from moisture.
- Inspect the stored flowmeter on a regular basis to ensure no condensation is present which may cause corrosion and /or damage to the electronics
- When other piping components and/or flow conditioners are provided with the meter, also apply a corrosion preventative coating to any uncoated surfaces.



Long term storage

When the meter is stored for longer time. Ensure that the meter is stored in a sheltered condition with a temperature between 0°C and + 60°C. The inside of the Flowbody should be protected from corrosion using a suitable corrosion preventive coating.



PROCON SYSTEMS (2013) INC.

9 Spare parts and accessories

Please contact Procon Systems (2013) Inc. for spare parts and accessories

DOCUMENT LPGX1 FLARE METER INSTRUCTION MANUAL	REVISION 1.0	REVISION DATE 2-JAN-2020	PAGE 31 OF 33
--	-----------------	-----------------------------	------------------



PROCON SYSTEMS (2013) INC.

Appendix A: Diagnostic Codes

Measurement Status / Transient Error

		Diagnostic Status Bits			set both AB/BA	Affects performance	WARNING	ERROR
		Hex Value	Decimal Value	Enum / Short Description				
MeasStatus	Values set for Meter Values	0x00000000	0	No_error	No Error			
		0x00000001	1	Warning	Measurement Warning		X	
		0x00000002	2	Error	Measurement Error			X
		0x00000004	4	CalSwitch_unlock	Calibration lock open			X
		0x00000008	8	System_error	Inconsistency in system parameters			X
		0x00000010	16	FPGA_error	Inconsistency in FPGA parameters			X
		0x00000020	32	Flash_mem_error	Error accessing internal flash memory			X
		0x00000040	64	RTCBattFail	RTC clock battery failure			X
		0x00000080	128	Ispare	Not enough power			X
		0x00001000	256	Firmware_error	Firmware checksum error			X
		0x00002000	512	Factory_defaults	Started from factory defaults			X
		0x00004000	1024	ParamCRC_Error	Parameter checksum error			X
		0x00008000	2048	Optionboard_timeout	Option board does not respond			X
		0x00010000	4096	TestMode	Meter is in test mode			X
		0x00020000	8192	DigOutOverflow	LF pulse output overflow			X
		0x00040000	16384	TotalStorageInitError	Totalizer storage error - no valid flash record found on startup			X
		0x00080000	32768	TotalPersistError	Totalizer persistence error - totalizer storage verification failed			X
0x00100000	65536	PTError	PTZ module error			X		

PTZ Module status

PTZStatus		0x00000000	0	PTStatusGood	PTZ No errors			
		0x00000001	1	PTStatusWarning	PTZ Warning		X	
		0x00000002	2	PTStatusError	PTZ Error			X
		0x00000004	4	Spare	spare			
		0x00000008	8	Spare	spare			
		0x00000010	16	TemperatureOutOfRangeError	Temperature sensor error or value out of range		X	
		0x00000020	32	PressureOutOfRangeError	Pressure sensor error or value out of range		X	
		0x00000040	64	PTReadTimeOutError	No response from PT option board			X
		0x00000080	128	PTZInputsOutOfRangeError	PTZ inputs out of range			X

Path / Transducer diagnostics

Path/ Transducer Status	Values set per transducer AB or BA	0x00000000	0	No error	No Error			
		0x00000001	1	Performance_bad	Performance too low			
		0x00000002	2	No_Correlation	MaxAmp and/or MinAmp below low limit		YES	
		0x00000004	4	SNR_Range	Signal to noise ratio too low		YES	
		0x00000008	8	Signal_overflow	Signal too large		YES	
		0x00000010	16	MinMaxZoom_Range	Min and Max indices of raw signal too far away		NO	
		0x00000020	32	Envelope_slope_range	Signal signature out of range		YES	
		0x00000040	64	Envelope_slope_dev	% deviation filter on Signal signature		YES	
		0x00000080	128	DetPoint_Range	Zero Cross out of range		YES	
		0x00001000	256	ZC_DETPT_Filter	Detectionpoint corrected by ZC_DETPT_filter		NO	
		0x00002000	512	DeltaT_error	ABS((DetPTCorrBA - DetPtCorrAB) - (ZeroCrossBA - ZeroCrossAB))		YES	
		0x00004000	1024	DemodTransittimeAccel	Transittime acceleration too high (cycle skip)		YES	
		0x00008000	2048	EnvPeakSkip	Envelope peak skip (packet)		NO	
		0x00010000	4096	SPARE				
		0x00020000	8192	SPARE				
		0x00040000	16384	SPARE				
		0x00080000	32768	SPARE				
		0x00100000	65536	VOSRange	Velocity of sound out of range	YES		X
		0x00200000	131072	VOGRange	Velocity of gas out of range	YES		X
		0x00400000	262144	WetGasVOS	Wetgas filter triggered substitution based on VOS	YES		X
		0x00800000	524288	WetGasVOG	Wetgas filter triggered substitution based on VOG	YES		X
		0x00100000	1048576	Substitution	Path being substituted based on historical data	YES		X
		0x00200000	2097152	SPARE				

DOCUMENT LPGX1 FLARE METER INSTRUCTION MANUAL	REVISION 1.0	REVISION DATE 2-JAN-2020	PAGE 32 OF 33
--	-----------------	-----------------------------	------------------

Appendix B: Field Wiring Diagram - C001756

