



# High Volume Blower Compressor





Unit Serial # GT 08-01-16-4

Blower Serial # S484232

CSA # 499261

## HIGH VOLUME BLOWER MANUAL

### Maintenance Guidelines and Requirements

Max Inlet Pressure .....	15 psi
Max RPM .....	2850
Grease Gear Box .....	Weekly (White Lithium with PTFE)
Blow Scrubbers Down .....	Daily
Oil in Blower .....	Keep at ½ site glass, CHECK DAILY <i>(use oil or other oil compatible to Enduratex Synthetic EP 220).</i>

### Operation

Adjust speed of Blower with speed handle on Hydraulic Pump operating Compressor to maintain a desired inlet pressure on unit. If Priority Valve is used, adjust using set screw on side of valve that is labeled for Compressor.

Compressor will engage and disengage based on Casing or Inlet pressure, being monitored by pressure switch on back wall of building. Adjust Speed to minimize cycling.

Compressor's set for pulling Negative pressure on Casing's should have Oxygen Sensors controlling and monitoring Unit.

Piping needs to be tested and checked for leaks. Casing Valves on wells should be plugged and locked in position.

When Loading wells that are Selling Gas to Compressor, they need to be isolated while loading is being done. Leave isolated for several hours before turning gas back in to unit.



## HIGH VOLUME BLOWER COMPRESSOR

### Increase Production by Reducing Wellhead Pressure

### Reduce Operating Costs

The High Volume Blower Compressor (HVBC) is ideally suited to improve performance of high volume, low pressure wells. HVBC increases the pressure of low pressure gas to a usable pressure, backing out propane usage while increasing well production

### Benefits

- Produce large volume of gas at lower pressure to supply multiple well pads
- Lowers wellhead pressure to enable increased production
- Economical to purchase and run
- Push gas into collections systems where pressures are low
- Boost lower pressure gas to 'back out' propane usage
- **Can be set up to run off existing skids and hydraulics**
- Low maintenance and user friendly

### Specifications

- 5HP Gardner Denver blower c/w 35cc hydraulic motor
- Two – 8" x 48" desiccant scrubbers c/w sight glass and drain
- Low gas pressure shut off sensor
- 13 PSI relief valve
- 12" x 12" Catadyne heater
- Pipe-fitted to exterior of building
- Class 1 Division 2 electrical
- 4' x 4' x 6' foam injected panel building
- Hinged roof on building

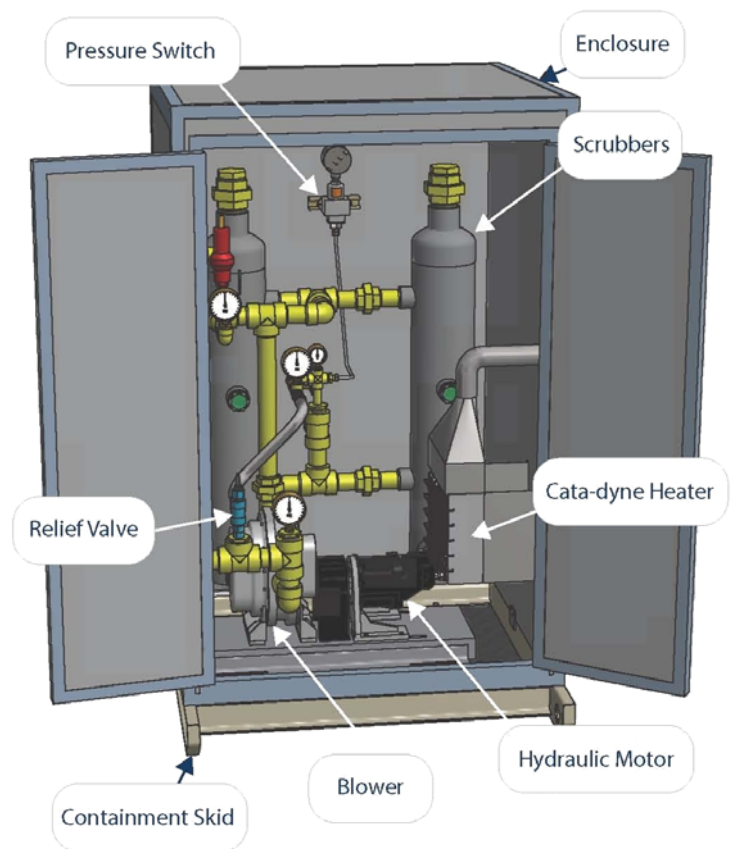



## PROVEN PERFORMANCE

Go-Technologies estimate of **Fuel Gas Savings** utilizing the High Volume Blower Compressor System instead of buying fuel gas from the natural gas co-op.

### **Scenario #1**

Gather and transfer 4 Deccs of casing gas venting from 2 wells to a battery site and use it for fuel gas.  
4 decs per day at \$144 per dec equals \$576 per day in expenses for the fuel gas used.  
This equates to \$210,240 per year.

### **Scenario #2**

Reduction or elimination of propane costs:  
A Single well battery with a 5.7 Chev engine skid plus two storage tanks with burners.  
Propane usage roughly 8% per day or higher during winter months which equates to 80 gallons per day or 364 liters.  
364 liters x.47 cents per liter = \$171 per day or \$5,132 per month and \$61,588 per year. Propane costs savings of \$33,488 would be realized.

### **Case Study #1**

High Volume Blower Compressor System installed on a well that was venting and could not be controlled by pinching back the casing valve, county gas was being used for fuel gas on the site. The casing pressure was pulled down to 1.5 PSI while maintaining 10-12 PSI on the fuel gas tree and the well production stabilized. Over a 3 month period the county gas system did not have to be used and the result was a savings of \$9,000 per month or \$27,000 in 3 months. This equates to \$108,000 per year in savings if all variables remain the same.

### **Case Study #2**

High Volume Blower Compressor System installed on a well that was carrying a steady 4.5 PSI on the casing which was not enough to effectively balance fluid level versus fuel gas use. The casing gas pressure was reduced to 1.5 PSI and 8 PSI discharge pressure and propane costs stopped in addition; the well produced an additional 2.1 M<sup>3</sup> of oil per day over the next month. The fluid level increased by 4-5 joints during this time. In this case if all variables remain the same a propane cost of \$48,000 per year will be eliminated and, as an added bonus, an increase in revenue from the additional oil production.



## Sutorbilt Legend - 3H

*Gas Application: Gardner denver must approve gas composition and blower must be specified for gas application. Please contact Gardner Denver Customer Service at 1-800-682-9868*



### Product Information

CORRECTED VALUES	ORIGINAL UNITS	ENGLISH UNITS	METRIC UNITS
Ambient Pressure	2500 ALTI-FT	13.397 PSIA	0.924 bar a
Elevation	2500 ALTI-FT	2500 ALTI-FT	762 alti-m
Inlet Pressure	13.397 PSIA	0.000 PSIG	0 bar g
Inlet Pressure Loss	0.3 PSIG	0.300 PSIG	0.021 bar g
Inlet Temp	15 F	15 °F	-9 °C
Inlet Flow	98 ICFM	98 ICFM	167 m³/h
Discharge Pressure	14 PSIG	14.000 PSIG	0.965 bar g
Discharge Pressure Loss	0.2 PSIG	0.200 PSIG	0.014 bar g
MEASURED VALUES	ORIGINAL UNITS	ENGLISH UNITS	METRIC UNITS
Speed	3088 RPM	3088 RPM	3088 RPM
RPM % Of Max	86	86	86
Power	9.6 HP	9.6 HP	7.2 kW
Discharge Temp	180 °F	180 °F	82 °C
Temp % of Max	56	56	56
Noise	89 dBa	89 dBa	89 dBa
Pressure % of Max	97	97	97

### PHYSICAL

Weight	82 lbs.
Gear Diameter / Center Distance	3.5 in.
Connection Size	1.25i/1.25d in.
Case Length	2.75 in.
WR <sup>2</sup>	0.258 lb-ft <sup>2</sup>
Orientation	horizontal

### PERFORMANCE

Max Delta P	15 PSI
Max Temp	320 °F
Max Speed	3600 RPM
Min Speed	1091 RPM
Max Case Pressure	25 PSIG
Max Delta T	220 °F

AMBIENT GAS PARAMETERS	ENGLISH UNITS	METRIC UNITS
Molecular Weight	39.930 lbm/lbmol	39.930 kg/kgmol
R Value	38.692 ft.lbf/lbm.R	0.208 kJ/kg.K
Density	0.105 lbm/ft <sup>3</sup>	1.682 kg/m <sup>3</sup>

GAS MIX:	VOL
Air	1.00%
Carbon Dioxide	85%
Methane	14%

## Performance Curves

### Temperature Rise

DEFINED CONDITIONS

**165 F**

RPM

3088

Published Data  
Defined Conditions

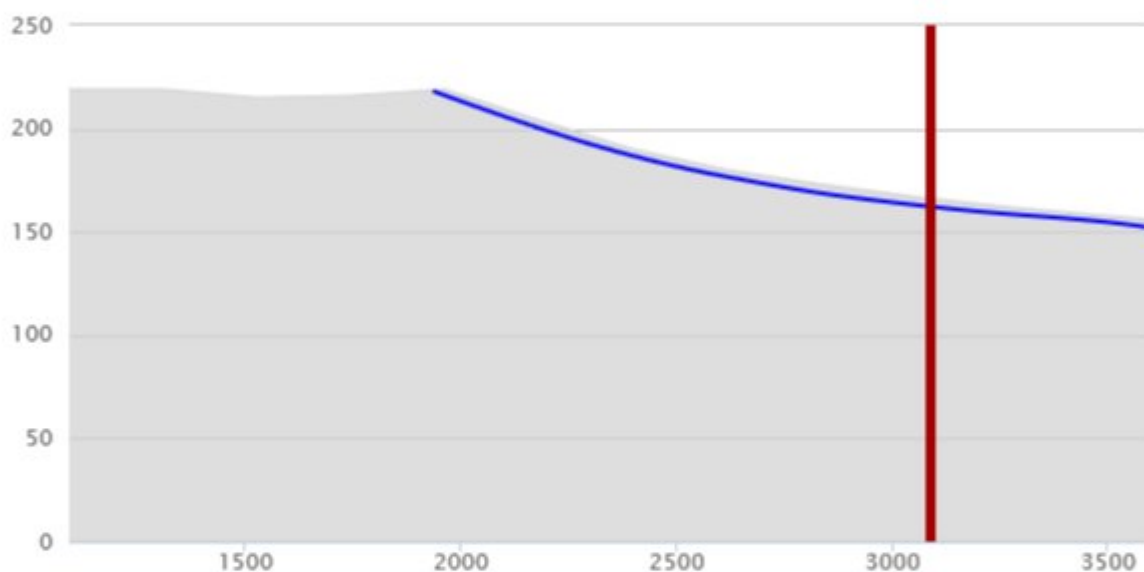

### Flow

DEFINED CONDITIONS

**97 ICFM**

RPM

3088

Published Data  
Defined Conditions

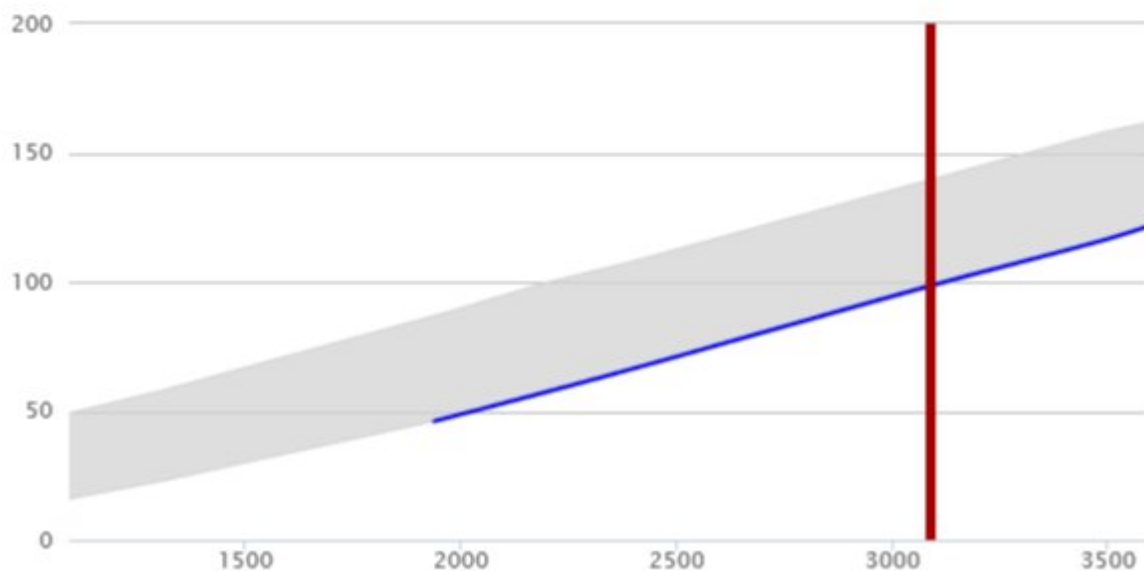



## Performance Curves

Power

DEFINED CONDITIONS

**9.6 HP**

RPM

3088

Published Data

Defined Conditions

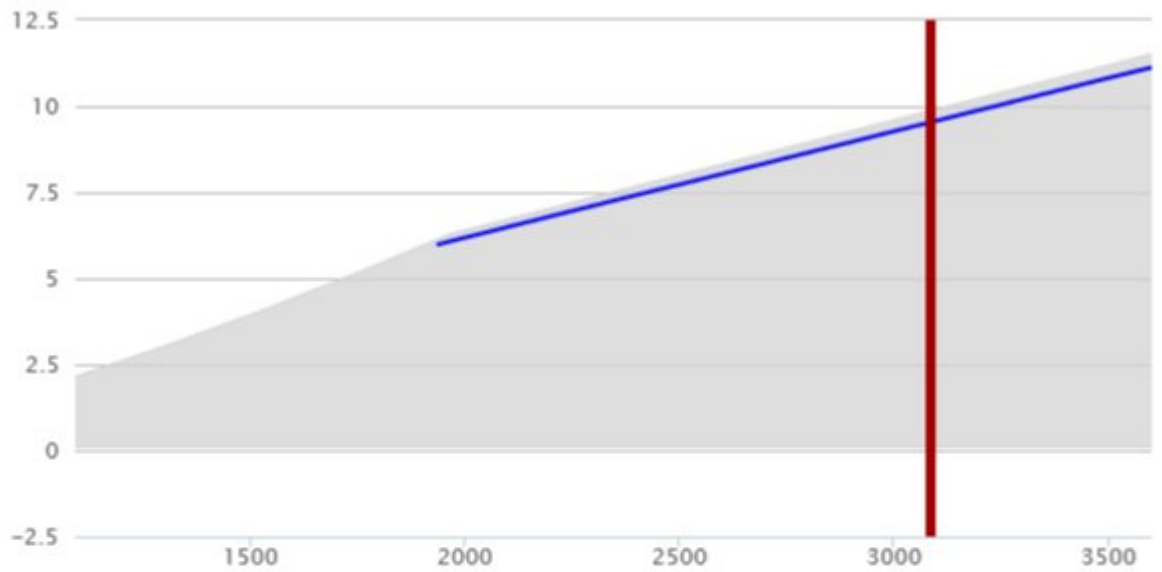

Torque

DEFINED CONDITIONS

**16.3 ft-lb**

RPM

3088

Published Data

Defined Conditions

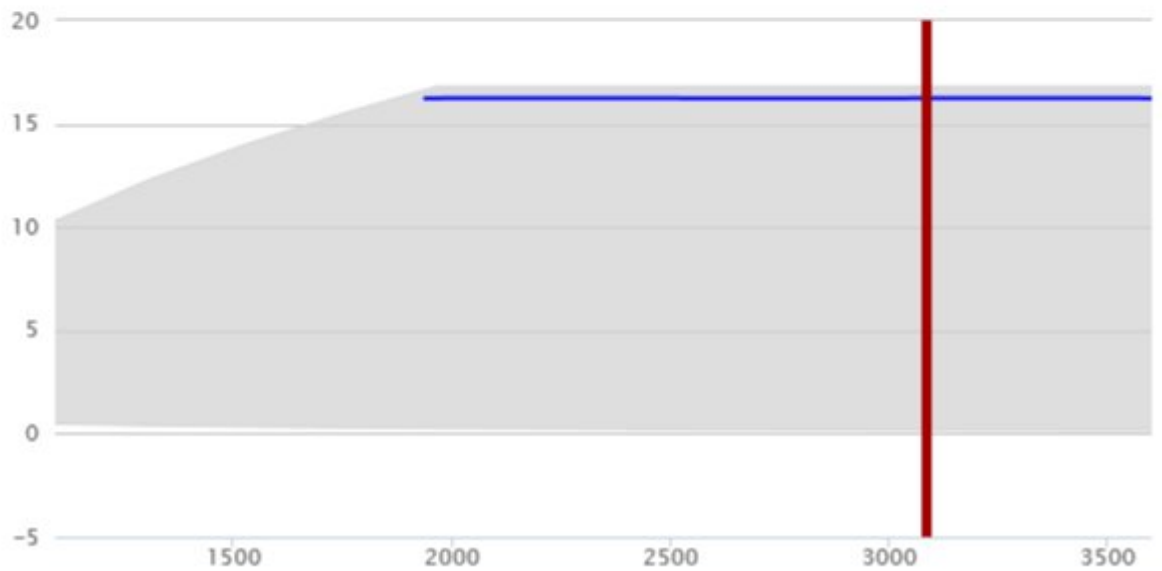

## Certificate Of Compliance

I Hereby Certify That The Below Registered Category "H" Pressure Fitting Has Been Designed, Manufactured, and Pressure Tested In Accordance With The Alberta Safety Codes Act, CSA B51 And ASME Section VIII, Division 1, 2013 Edition.

CRN	0H12502.21345				
S/N	8285.3715				
Diameter	8.625	Inches	Overall Length	48	Inches
Year Built	2015				
MAWP	285	PSIG	@	650	°F
MDMT	-20 °F				
C.A.	0.125	Inches			
Radiography	N/A				
PWHT : Time	N/A	min.	Temp.	-	°F
Hydro Tested @	375	PSIG			

	Material	Thickness
Shell	SA-106 Gr. B	Sch 40 - 0.322"
Head 1	SA-234 WPB	Sch 40 - 0.322"
Head 2	SA-516 Gr. 70N	0.75"



Quality Control Manager  
Dennis Klococki

July 28, 2015





CustomControlSensors

# Hazardous Areas Adjustable Pressure Switch

## 646V\*E\* & 646GV\*E - Diaphragm Sensor

### DESCRIPTION

- Highly reliable devices utilizing the CCS Dual-Snap® Belleville disc spring principle pioneered by CCS' engineers.
- Engineering based on aerospace technology.
- Rigid, midsize and internally adjustable for convenient field set point adjustment.
- Repeatable and stable set points.
- Vibration and shock resistant.
- High cycle life.
- High over-pressure capability. (System and Proof)
- Certified explosion proof hermetically sealed electrical assembly for environmental protection.
- Various options for wetted materials and electrical ratings to meet a wide range of application requirements and media compatibility.
- Suitable for ultra low pressure and vacuum to pressure applications.

SHIPPING WEIGHT: APPROXIMATELY 56 OUNCES (1587 GRAMS)

### SERIES:

- 646V\*E\*
- 646GV\*E\*

### ADJUSTABLE SET POINT RANGE:

#### VACUUM:

- 1 to 28.5" Hg
- 25 to 724 mm Hg

#### CROSSOVER:

- 20" Hg Vacuum to 12 PSIG
- 508 mm Hg to 0.83 bar

### OPERATING TEMPERATURE:

Temperature limits change with O-ring selection.

- 40° to 186°F
- 40° to 86°C

### STANDARD FEATURES:

- Hermetically Sealed Electrical Assembly
- CE Mark
- Dual Seal: ANSI/ISA-12.27.01
- NACE MRO175 / ISO 15156
- NEMA: 4, 7, 9, 13 / IP66
- CRN
- U.L. / CSA Listed



### INSTALLATION DRAWING

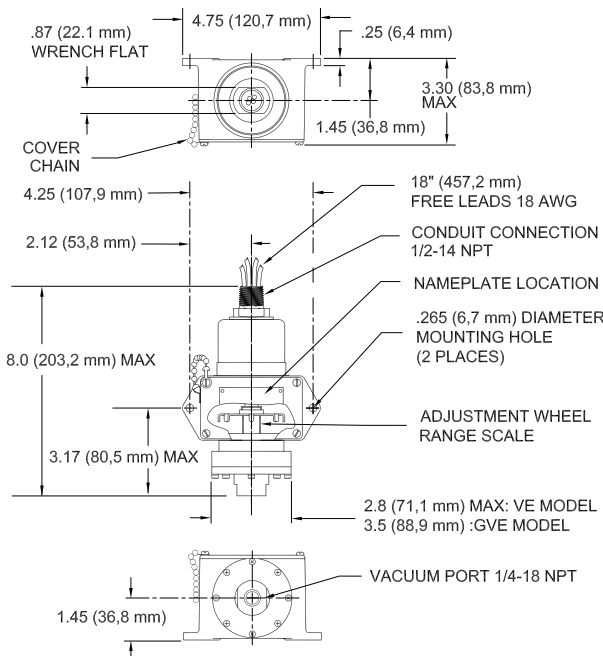

### DESIGN PRINCIPLES

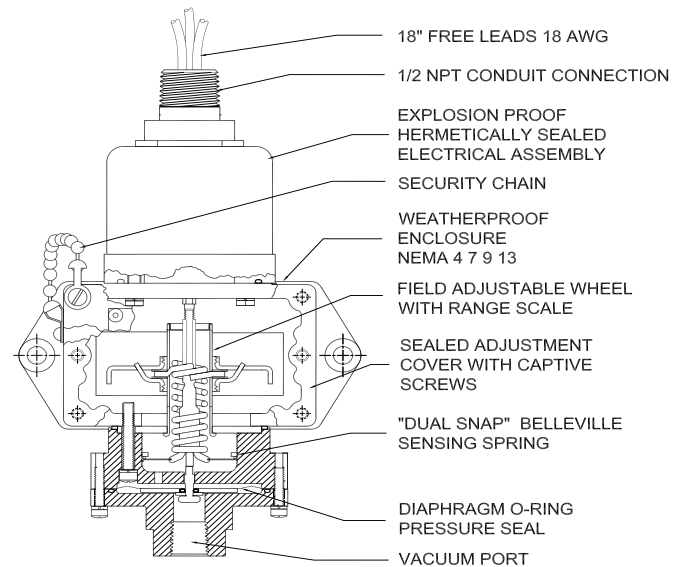

### 646VE & GVE SERIES

**FIELD SETTING:** Open access cover. Turn clockwise to increase settings. Counterclockwise to decrease settings.

**NOTE:** DO NOT USE ELECTRICAL HEX FOR TORQUING.



CustomControlSensors

# Hazardous Areas Adjustable Pressure Switch

## 646V\*E\* & 646GV\*E - Diaphragm Sensor

### OPERATING AND ORDERING DATA

SERIES 646VE*	WETTED PARTS: 1/4"-18 NPT ALUMINUM PRESSURE PORT, POLYIMIDE DIAPHRAGM , BUNA N O-RING									
	ADJUSTABLE SET POINT RANGE				APPROX. DEAD BAND INCHES Hg (mm Hg)	SYSTEM PRESSURE PSIG (BAR)	PROOF PRESSURE PSIG (BAR)			
	INCREASING VACUUM INCHES Hg (mm Hg)		DECREASING VACUUM INCHES Hg (mm Hg)							
646VE*1	3.5-28.5 (89-724)		1-26 (25-660)		2.5 (64)	150 (10.3)	250 (17.2)			
SERIES 646VZE*	WETTED PARTS: 1/2"-14 NPT 316 STAINLESS STEEL PRESSURE PORT, POLYIMIDE DIAPHRAGM, VITON O-RING									
	ADJUSTABLE SET POINT RANGE				APPROX. DEAD BAND INCHES Hg (mm Hg)	SYSTEM PRESSURE PSIG (BAR)	PROOF PRESSURE PSIG (BAR)			
	INCREASING VACUUM INCHES Hg (mm Hg)		DECREASING VACUUM INCHES Hg (mm Hg)							
646VZE*1	3.5-28.5 (89-724)		1-26 (25-660)		2.5 (64)	150 (10.3)	250 (17.2)			
SERIES 646GVE* CROSSOVER (VACUUM TO GAGE)	WETTED PARTS: 1/4"-18 NPT ALUMINUM PRESSURE PORT, POLYIMIDE DIAPHRAGM , BUNA N O-RING									
	ADJUSTABLE SET POINT RANGE VACCUM		APPROX. DEAD BAND INCHES Hg (mm Hg) VACCUM		ADJUSTABLE SET POINT RANGE GAGE PRESSURE		APPROX. DEAD BAND PSI (BAR) GAGE PRESSURE		SYSTEM PRESSURE PSIG (BAR)	PROOF PRESSURE PSIG (BAR)
	INCREASING VACUUM INCHES Hg (mm Hg)	DECREASING VACUUM INCHES Hg (mm Hg)	AT TOP OF RANGE	AT BOTTOM OF RANGE	INCREASING PRESSURE PSI (BAR)	DECREASING PRESSURE PSI (BAR)	AT TOP OF RANGE	AT BOTTOM OF RANGE		
646GVE*2	1.5-18 (38-457)	0.5-17 (3-493)	1.0 (25)	1.0 (25)	1.0-10 (0.068-0.68)	0.5-9.5 (0.034-0.65)	0.5 (0.034)	0.5 (0.034)	500 (34.5)	750 (52)
SERIES 646GVZE* CROSSOVER (VACUUM TO GAGE)	WETTED PARTS: 1/4"-18 NPT STAINLESS STEEL PRESSURE PORT, POLYIMIDE DIAPHRAGM, VITON O-RING									
	ADJUSTABLE SET POINT RANGE VACCUM		APPROX. DEAD BAND INCHES Hg (mm Hg) VACCUM		ADJUSTABLE SET POINT RANGE GAGE PRESSURE		APPROX. DEAD BAND PSI (BAR) GAGE PRESSURE		SYSTEM PRESSURE PSIG (BAR)	PROOF PRESSURE PSIG (BAR)
	INCREASING VACUUM INCHES Hg (mm Hg)	DECREASING VACUUM INCHES Hg (mm Hg)	AT TOP OF RANGE	AT BOTTOM OF RANGE	INCREASING PRESSURE PSI (BAR)	DECREASING PRESSURE PSI (BAR)	AT TOP OF RANGE	AT BOTTOM OF RANGE		
646GVZE*2	1.5-18 (38-457)	0.5-17 (3-493)	1.0 (25)	1.0 (25)	1.0-10 (0.068-0.68)	0.5-9.5 (0.034-0.65)	0.5 (0.034)	0.5 (0.034)	500 (34.5)	750 (52)

### HOW TO ORDER

Follow these steps to build your part number:

1. Specify the series based on your required set point, range, dead band, system pressure and proof pressure.
2. Add desired options model code letter.
3. Add the applicable standard suffix number.

(Ex: 646GVZE2-7008)

### PRESSURE CONVERSION

1 BAR = 14.5 PSI  
1 kPa = 0.145 PSI

### CERTIFICATIONS

Consult CCS website for complete certification and approval listing.

### OPTIONAL STANDARD MODIFIED SUFFIXES

- 7005:** Viton/Dacron Diaphragm, Viton O-Ring & Stainless Steel Port Cap (VZ Models only)
- 7008:** Gold Contacts
- 7011:** Stainless Steel Port and Diaphragm
- 7054:** 2 Meter Free Leads
- 7076:** 18 inch Teflon Free Leads (Low Temp Wire)

Note: Additional modified standard suffixes are available, consult CCS sales department or CCS Representative.

### ELECTRICAL ENCLOSURE CERTIFICATIONS

- \* c-UL, U.L./CSA Explosion Proof: Div. 1, 2 hermetically sealed electrical assembly P/N 17-51 (17-73 for M model option), listed by both Underwriter's Laboratories, Inc. (File No. E32961) and Canadian Standard Association (CSA) Testing Laboratories (File No. LR22921) for hazardous locations, Class 1, Groups A, B, C, and D; Class 2 Groups E, F, and G.
- \* ATEX - Baseefa certified for potentially explosive atmospheres. Models 646\*\*Y, II 2 GD Ex d IIC, Baseefa 05ATEX0011X. (Option Y)

### OPTIONS MODEL CODES

- A:** Viton® O-Ring (STD on GVZE models)
- F:** Ethylene Propylene O-Ring
- M:** DPDT Electrical
- Y:** ATEX / GOST Certified Electrical Assembly (Consult CCS Sales Department for GOST options and requirements.)
- X:** Double Break Electrical Assembly

### ELECTRICAL CHARACTERISTICS RATING OF SWITCH ELEMENT

VOLTS	AMPERES		
	SPDT	DPDT "M"	Dbl Brk "X"
	Res.	Res.	Res.
125 AC - 50/60 Hz	15	5	15
250 AC - 50/60 Hz	15	5	15
480 AC - 50/60 Hz	15	-	15
28 DC	-	5	-
125 DC	.5	.5	1
250 DC	.2	-	.5
*125 AC - 50/60 Hz	1 max	1 max	-
*30 DC	1 max	1 max	-

\*Gold Contacts -7008 Suffix

### SCHEMATIC AND WIRING CODE

Note: In gage mode, wiring diagram will be in reverse.

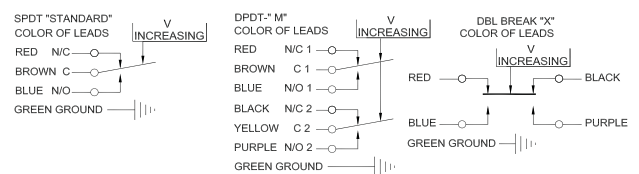



CustomControlSensors

# Hazardous Areas Adjustable Temperature Switch

## 6900TE\* - Probe

### DESCRIPTION

- Highly reliable devices utilizing the CCS Dual-Snap® Belleville disc spring principle pioneered by CCS' engineers.
- Engineering based on aerospace technology.
- Rigid, compact and internally adjustable for convenient field set point adjustment.
- Repeatable and stable set points.
- Vibration and shock resistant.
- High cycle life.
- High over-temperature capability. (System and Proof)
- Certified explosion proof hermetically sealed electrical assembly for environmental protection.
- Various options for electrical ratings to meet a wide range of application requirements.

SHIPPING WEIGHT: APPROXIMATELY 32 OUNCES (907 GRAMS)

### SERIES:

6900TE\*

### ADJUSTABLE SET POINT RANGE: TEMPERATURE:

0° to 405°F  
-18° to 207°C

### OPERATING TEMPERATURE:

-40° to 186°F  
-40° to 86°C

### STANDARD FEATURES:

- CE Mark
- CCC
- Dual Seal: ANSI/ISA-12.27.01
- NACE MR0175 / ISO 15156
- NEMA: 4, 7, 9, 13 / IP66
- U.L. / CSA Listed
- Hermetically Sealed Electrical Assembly
- 316 SST Electrical Assembly



### INSTALLATION DRAWING

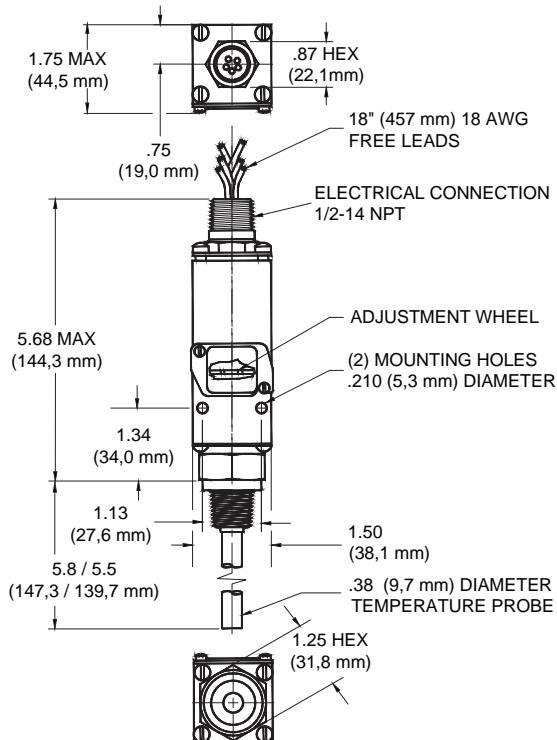

### DESIGN PRINCIPLES

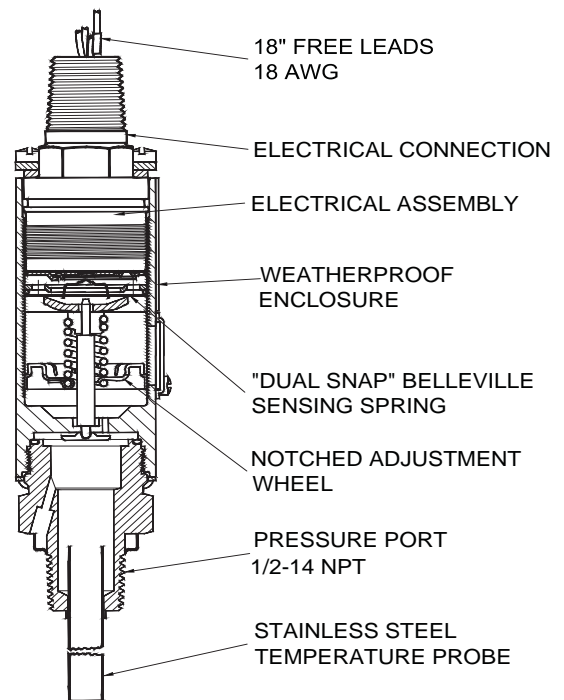

SERIES 6900TE

**FIELD SETTING:** Loosen access cover. Adjust adjustment screw using screwdriver slot as illustrated, then attach to a variable pressure source with a suitable gage, and check that the circuit continuity operates at the pressures desired. Clockwise to increase settings. Counterclockwise to decrease setting.

**NOTE:** DO NOT USE ELECTRICAL HEX FOR TORQUING.





CustomControlSensors

# Hazardous Areas Adjustable Temperature Switch

## 6900TE\* - Probe

### OPERATING AND ORDERING DATA

SERIES 6900TE*	WETTED PARTS: 300 STAINLESS STEEL TEMPERATURE PROBE				
	ADJUSTABLE SET POINT RANGE		APPROXIMATE DEAD BAND		MAXIMUM PROBE TEMPERATURE DEGREES F (DEGREES C)
	INCREASING TEMPERATURE DEGREES F (DEGREES C)	DECREASING TEMPERATURE DEGREES F (DEGREES C)	AT BOTTOM OF RANGE DEGREES F (DEGREES C)	AT TOP OF RANGE DEGREES F (DEGREES C)	
6900TE*12	+20° to +120° (-7° to +49°)	+0° to +113° (-18° to +45°)	20° (11°)	5° (4°)	+200° (+93°)
6900TE*14	+80° to +205° (+27° to +96°)	+60° to +198° (+16° to +92°)	20° (11°)	5° (4°)	+300° (+149°)
6900TE*16	+185° to +315° (+85° to +157°)	+165° to +308° (+74° to +153°)	20° (11°)	5° (4°)	+400° (+204°)
6900TE*18	+280° to +405° (+138° to +207°)	+260° to +398° (+127° to +203°)	20° (11°)	5° (4°)	+500° (+260°)

EXTERNAL PROBE PRESSURE:

**System Pressure: 1250 PSIG (86 bar)      Proof Pressure: 1500 PSIG (103 bar)**

### HOW TO ORDER

Follow these steps to build your part number:

1. Specify the series based on your required set point, range, dead band, system pressure and proof pressure.
2. Add desired options model code letter.
3. Add the applicable standard suffix number.

(Ex: 6900TEM16-7042)

### TEMPERATURE CONVERSION

32 Deg F = 0 Deg C

### OPTIONAL STANDARD MODIFIED SUFFIXES

- 7008:** Gold Contacts
- 7042:** Stainless Steel Body
- 7054:** 2 Meter Free Leads
- 7076:** 18 inch Teflon Free Leads (Low Temp Wire)

### OPTIONS MODEL CODES

- M:** DPDT Electrical
- Y:** ATEX / GOST Certified Electrical Assembly (Consult CCS Sales Department for GOST options and requirements.)

### THERMOWELLS

Order as separate line items. See accessory page for detailed information.

- 113-34-2:** 1" NPT 316 SST 7.5" "U" Dim.
- 113-35-2:** 3/4" NPT 316 SST 7.5" "U" Dim.

### CERTIFICATIONS

Consult CCS website for complete certification and approval listing.

### ELECTRICAL ENCLOSURE CERTIFICATIONS

\* c-UL, U.L./CSA Explosion Proof: Div. 1, 2 hermetically sealed electrical assembly P/N 46-1058 (46-1061 for M model option), listed by both Underwriter's Laboratories, Inc. (File No. E32961) and Canadian Standard Association (CSA) Testing Laboratories (File No. LR22921) for hazardous locations, Class 1, Groups A, B, C, and D; Class 2 Groups E, F, and G.

\* ATEX certified for potentially explosive atmospheres electrical assembly series 46-XXXXXXX, Models 6\*\*\*\*, Ex d IIC T6, Directive 94/9/EC Sira 08ATEX1046X. (Option Y)

\* IECEx - SIRA certified, SIR 10,0193X (Option Y)

### ELECTRICAL CHARACTERISTICS SCHEMATIC AND WIRING CODE

VOLTS	RATING OF SWITCH ELEMENT	
	AMPERES	
	SPDT Res.	DPDT "M" Res.
125 AC - 50/60 Hz	11	11
250 AC - 50/60 Hz	11	11
30 DC	5	5
125 DC	.5	.5
*125 AC - 50/60 Hz	1 max	1 max
*30 DC	1 max	1 max

\*Gold Contacts -7008 Suffix

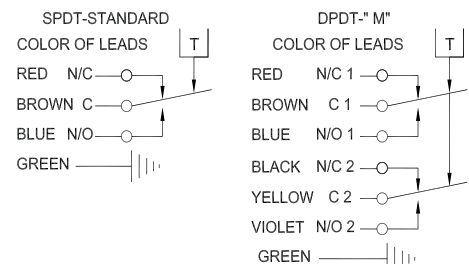

*Note: Additional modified standard suffixes are available, consult CCS sales department or CCS Representative.*

# SPECIFICATION



2016-06-07 11:14

File Name CCL200-0218

Project No.

Customer Wajax

Project

Notes Hydraulic fan drive

Geometric data

Core height	400.0 [mm]
Core width	393.3 [mm]
Core depth	63.0 [mm]
Fouling Factor	0.0%
Fitting	38 [mm]
Cooler type	Plate-fin/fin
Plate-fin/fin	7101 / 7318
Flow	Crossflow I-Flow I-Flow

**Total heat transfer rate: (approx.) 4.4 [kW]**

Warm fluid: natural gas L

Properties at 82.6[°C]

Density	0.64 [kg/m <sup>3</sup> ]
specific heat	2.068 [kJ/kg K]
kinemat. viscosity	21.34 [mm <sup>2</sup> /s]

Flow rate	102.8 [cfm]
Temperature in	120 [°C]
Temperature out	45.152 [°C]
Inlet pressure	14.504 [psi]
Pressure drop	0.21 [psi]

Cold fluid: Air

Fan 11.75/6-6/30/2H (298.45mm sucking)

ΔP from Fan / built-in resistance 0.73 0 [mbar]

Fan speed / Power	1750 [rpm]	0.06 [hp]
Fan-Density		1.1 [kg/m <sup>3</sup> ]

Flow rate	869.6 [cfm]
Temperature in	37 [°C]
Temperature out	46.565 [°C]
Inlet pressure	406.78 [inchH20]
Pressure drop	0.293 [inchH20]
Elevation (ASL)	0 [m]

Load carrying ability According to AKG test conditions

Installation & operating see instruction for installation and operation of AKG-Products

Date:6/7/2016 Signature

K-1/ V-1.7.2.6 / 4/7/2016





**Sunfab's SCM 010-130 SAE is a range of robust axial piston motors especially suitable for mobile hydraulics.**

SCM 010-130 SAE is of the bent-axis type with spherical pistons. The design results in a compact motor with few moving parts, high starting torque and high reliability. It covers the entire displacement range 10-130 cm<sup>3</sup>/rev. at a maximum pressure of 400 bar. It features double tapered roller bearings, which permits high shaft loads and gives superb speed performance.

The high level of reliability is based on the choice of materials, hardening methods, surface structures and the quality assured manufacturing process.

Sunfab also offers a two-bolt flange, SAE B2 010- 034 in the SCM family. The design features double tapered roller bearings, which permits high shaft loads and gives superb speed performance.

**Other advantages:**

- High maximum speed
- Smooth operation over the entire speed range
- Available in many different configurations of shafts and connections
- High efficiency
- Speed sensor available as option
- Suitable for applications with high angular accelerations due to its high rotary stiffness

Motor SCM 010-130 SAE		010	012	017	025	025	034	034	040	047	056	064	084	084	090	090	108	108	130	
		SAE B	SAE B	SAE B	SAE B	SAE C	SAE B	SAE C	SAE C	SAE C	SAE C	SAE C	SAE C	SAE D	SAE C	SAE D	SAE C	SAE D	SAE D	
Displacement	cm <sup>3</sup> /rev	9.6	12.6	17.0	25.4	25.4	34.2	34.2	41.2	47.1	56.7	63.5	83.6	83.6	90.7	90.7	108.0	108.0	130.0	
Working pressure																				
max intermittent	bar	400	400	400	400	400	400	400	400	400	400	400	400	400	400	400	400	400	400	350
max continuous		350	350	350	350	350	350	350	350	350	350	350	350	350	350	350	350	350	350	300
Revolutions																				
max intermittent	rpm	8250	8250	8250	6500	6500	6500	6500	5900	5900	5900	5900	4800	4600	4800	4600	4800	4600	4600	4600
max continuous		7500	7500	7500	5900	5900	5900	5900	5300	5300	5300	5300	4400	4200	4400	4200	4400	4200	4200	4200
min continuous		300	300	300	300	300	300	300	300	300	300	300	300	300	300	300	300	300	300	300
Power																				
max intermittent	kW	41	50	70	80	80	110	110	120	135	165	180	200	190	215	205	255	245	245	255
max continuous		15	20	25	40	40	55	55	60	65	80	90	100	100	110	110	130	130	135	135
Starting torque theoretical value	Nm/bar	0.15	0.20	0.27	0.40	0.40	0.54	0.54	0.66	0.75	0.89	1.00	1.33	1.33	1.44	1.44	1.71	1.71	1.71	2.06
Mass moment of inertia (x 10 <sup>-3</sup> )	kg m <sup>2</sup>	0.9	0.9	0.9	1.1	1.1	1.1	1.1	2.6	2.6	2.6	2.6	6.3	7.4	6.3	7.4	6.3	7.4	7.4	7.4
Weight	kg	9.0	9.0	9.0	9.0	9.0	9.0	9.0	15.0	15.0	15.0	15.0	18.0	35.0	18.0	35.0	18.0	35.0	35.0	35.0

Data concerning RPM are based on maximum permitted peripheral velocity of the tapered roller bearing.  
 Max intermittent power data may vary dependent on application. For further information please contact Sunfab.  
 Continuous power data are based on maximum output power without external cooling of the motor housing.  
 Intermittent duty is defined as follows: max 6 seconds per minute, e.g peak RPM when unloading or accelerating.

# Versions, main data

Example

SC	M	012	W	N	SB4	B13	S3	U	1	00
Line	1	2	3	4	5	6	7	8	9	10

Line	SC	Sunfab Compact, bent-axis design
------	----	----------------------------------

1. Type	M	Motor
---------	---	-------

2. Displacement	010	012	017	025	034	040	047	056	064	084	090	108	130
-----------------	-----	-----	-----	-----	-----	-----	-----	-----	-----	-----	-----	-----	-----

3. Direction of rotation	W	Independent
--------------------------	---	-------------

4. Sealing	N	Nitrile
	H	High pressure, nitrile
	V	Viton

5. Mounting flange	SAE J-744	010	012	017	025	034	040	047	056	064	084	090	108	130
SB2	SAE B-2 hole	X	X	X	X	X	-	-	-	-	-	-	-	-
SB4	SAE B-4 hole	X	X	X	X	X	-	-	-	-	-	-	-	-
SC4	SAE C-4 hole	-	-	-	X	X	X	X	X	X	X	X	X	-
SD4	SAE D-4 hole	-	-	-	-	-	-	-	-	-	X	X	X	X

6. Shaft	010	012	017	025	034	040	047	056	064	084	090	108	130
Spline SAE J498b 30° Class 5													
B13	13T 16/32	X	X	X	X	X	-	-	-	-	-	-	-
C14	14T 12/24*	-	-	-	X	X	X	X	X	X	O	O	-
C21	21T 16/32*	-	-	-	-	-	X	X	X	X	X	X	-
D13	13T 8/16**	-	-	-	-	-	-	-	-	-	X	X	X
Key SAE J744													
B25	∅ 25.4	X	X	X	X	X	-	-	-	-	-	-	-
C32	∅ 31.7*	-	-	-	-	-	X	X	X	X	O	O	O
D44	∅ 44.45**	-	-	-	-	-	-	-	-	-	X	X	X

\* Only with SC4 mounting flange  
 \*\* Only with SD4 mounting flange

X = Standard, preferred  
 (X) = Available, option  
 O = Contact Sunfab

7. Connection cover		010	012	017	025	034	040	047	056	064	084	090	108	130
S1	40° Mount flange vertical *	-	-	-	-	-	-	-	-	-	X	X	X	X
S2	40° Mount flange horizontal *	-	-	-	-	-	X	X	X	X	-	-	-	-
S3	40° threaded connection	X	X	X	X	X	-	-	-	-	-	-	-	-
V1	90° Mount flange vertical *	-	-	-	-	-	-	-	-	-	X	X	X	X
V2	90° Mount flange horizontal *	-	-	-	X	X	X	X	X	X	X	X	X	X
R1	Side connections, flanged *	-	-	-	X	X	X	X	X	X	X	X	X	X
K3	Combicover 90° side conn. thread .	X	X	X	X	X	-	-	-	-	-	-	-	-

\* According to SAE J518 code 62

8. Connections		010	012	017	025	034	040	047	056	064	084	090	108	130
G	ISO G*	X	X	X	X	X	-	-	-	-	-	-	-	-
M	Metric **	-	-	-	X	X	X	X	X	X	X	X	X	X
U	UN***	X	X	X	X	X	X	X	X	X	X	X	X	X

\* Only threaded connections  
 \*\* Only flanged connections  
 \*\*\* Only available for S covers

9. Additional	1	External drainage
---------------	---	-------------------

10. Speed sensor		010	012	017	025	034	040	047	056	064	084	090	108	130
00	No speed sensor	X	X	X	X	X	X	X	X	X	X	X	X	X
P1	Prepared for speed sensor	X	X	X	X	X	X	X	X	X	X	X	X	X
S1	Fitted speed sensor type PNP*	X	X	X	X	X	X	X	X	X	X	X	X	X
S2	Fitted speed sensor type NPN*	X	X	X	X	X	X	X	X	X	X	X	X	X

\* See separate brochure "Speed sensor hall" for more information.

# Dimensions SCM 010-034 SAE B2

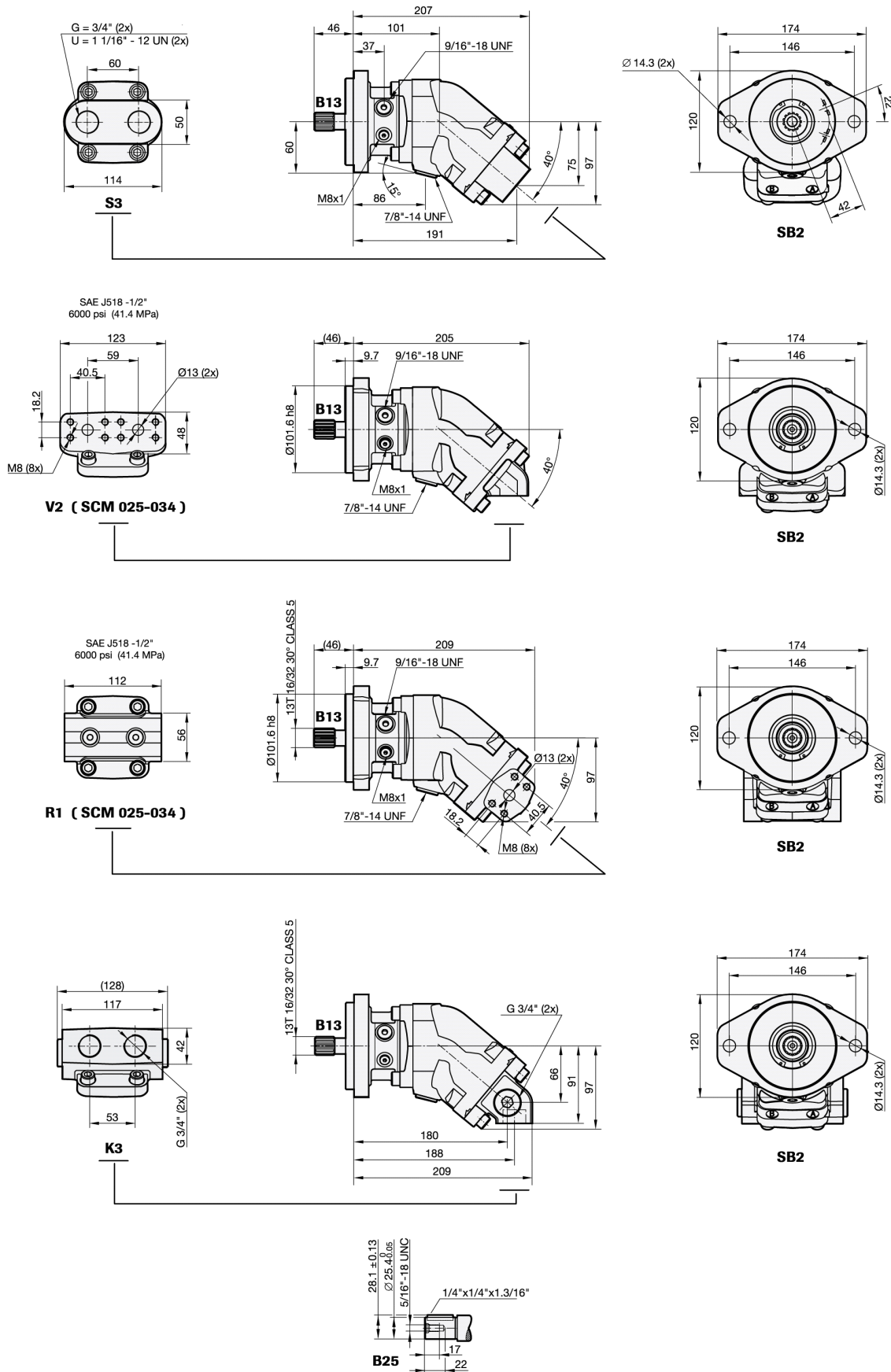

SCM 010-034 SAE B4

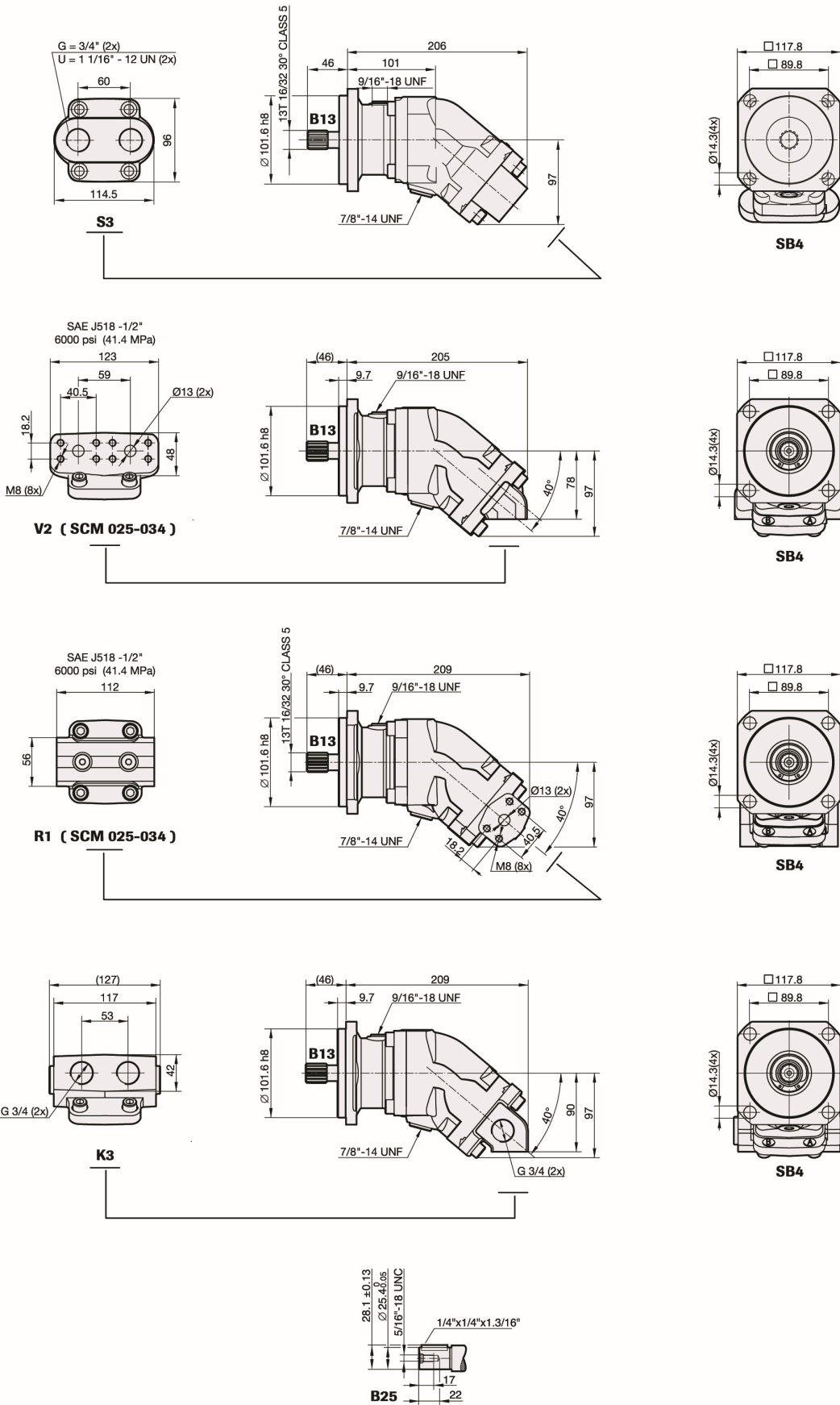

SCM 040-064 SAE C

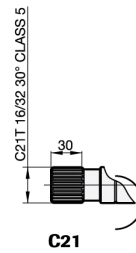
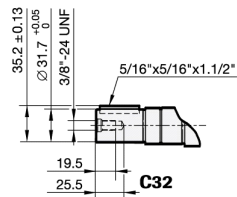
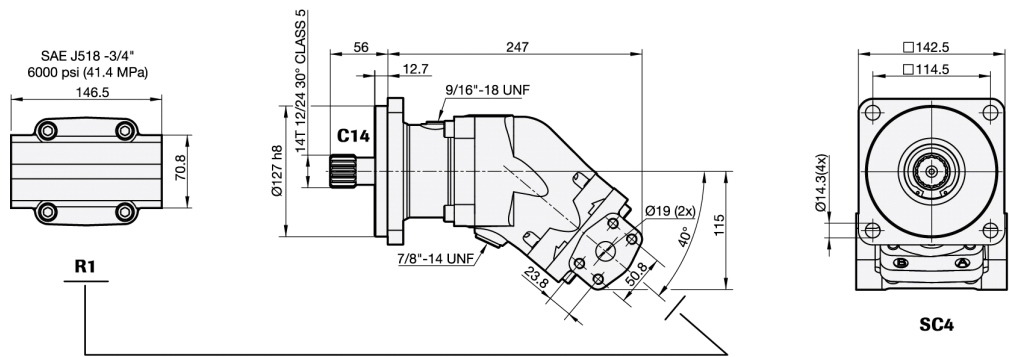
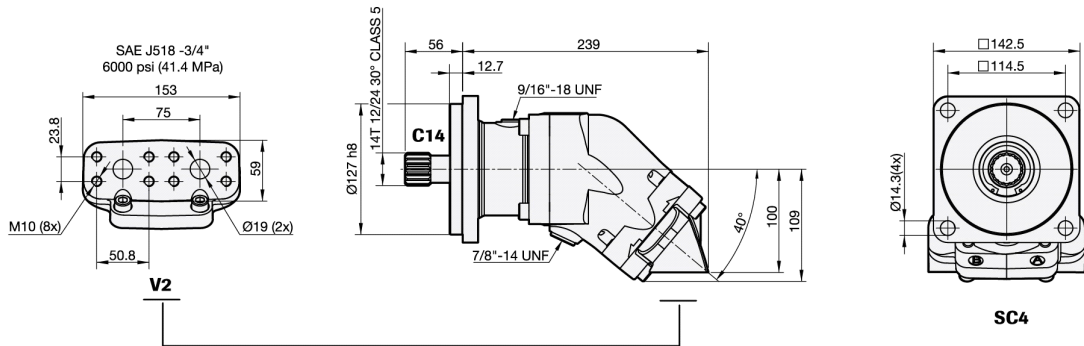
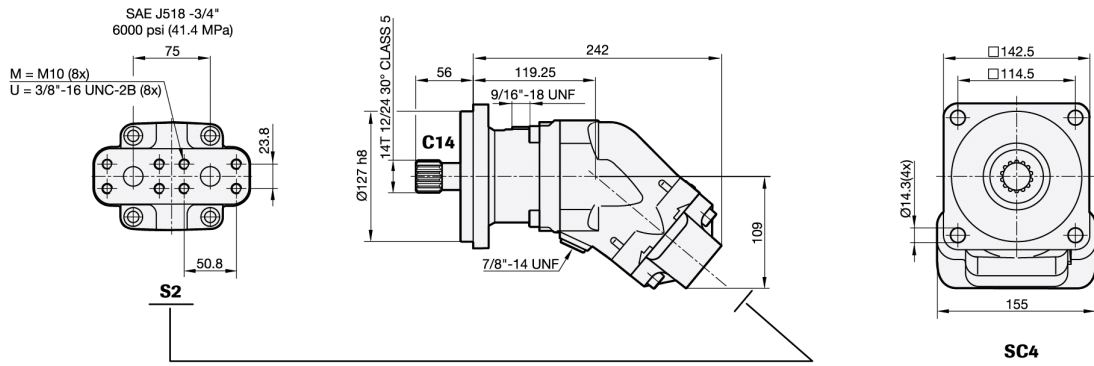



SCM 084-108 SAE C

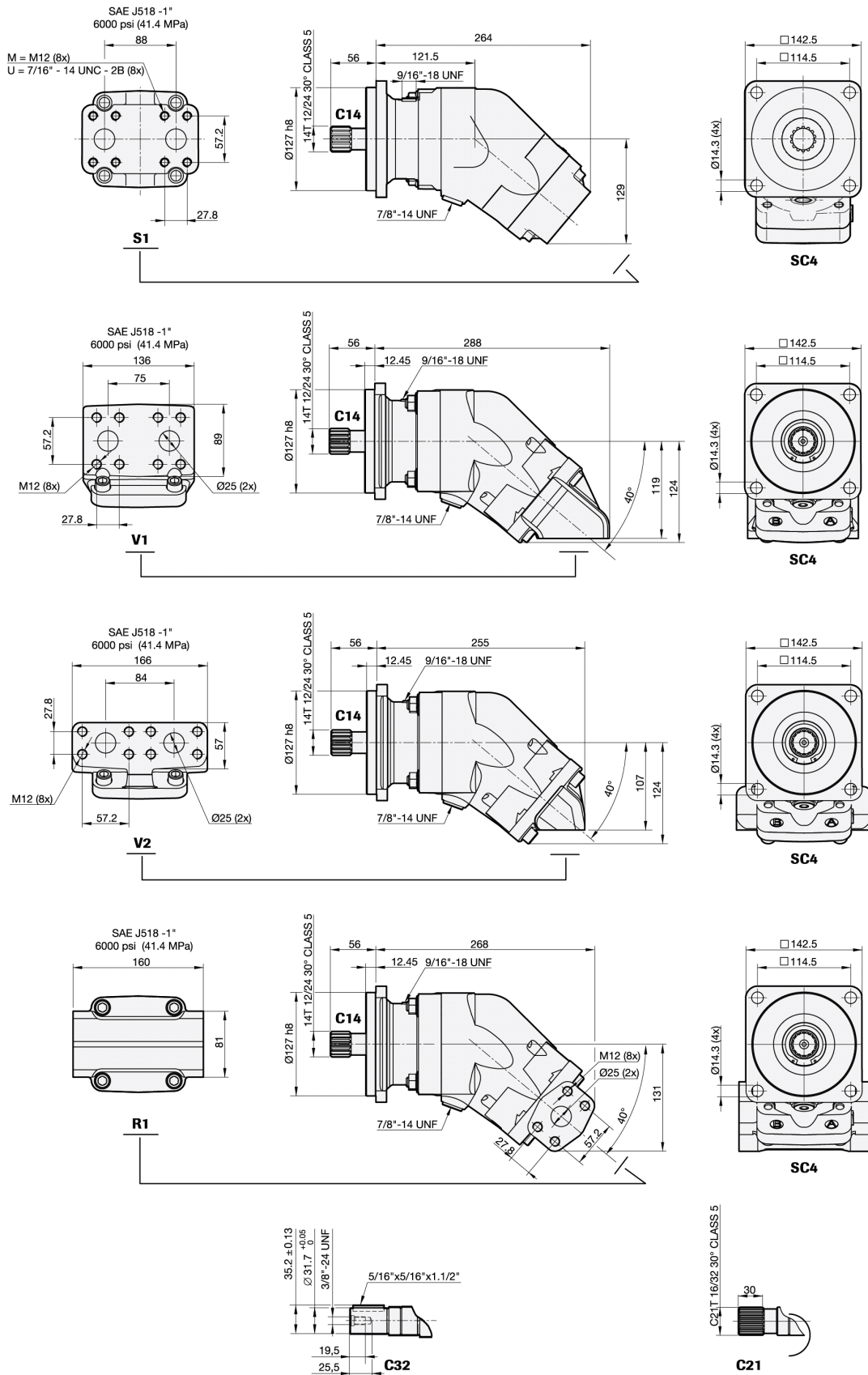

# SCM 084-130 SAE D

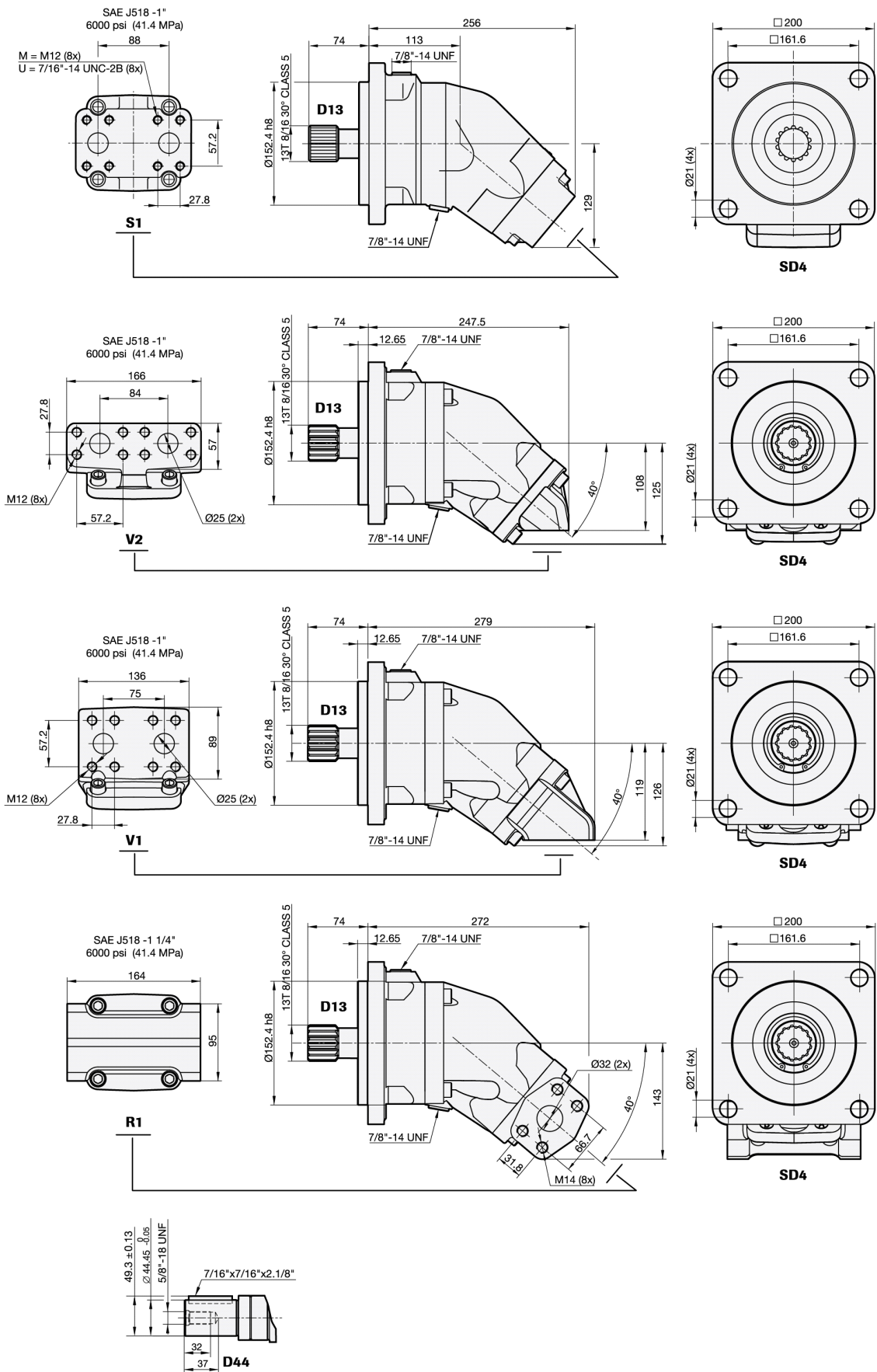

## General instructions

### Choice of shaft seal

Motor SCM	Code	Temp.	Max. housing pressure bar at rpm				
		°C	1000	2000	3000	4000	5000
010-034 B	N	75	5.5	2.7	1.8	1.4	1.1
	H	75	24,6	12,3	8.2	6.1	5.1
	V	90	5.5	2.7	1.8	1.4	1.1
040-108 C	N	75	5.5	2.7	1.8	1.4	1.1
	H	75	24,6	12,3	8.2	6.1	5.1
	V	90	5.5	2.7	1.8	1.4	1.1
084-130 D	N	75	3.5	1.7	1.2		
	H	75	15,6	7,8	5.2		
	V	90	3.5	1.7	1.2		

Code according to page 2, Versions, main data

Factors affecting the choice of shaft seal include the hydraulic motor housing pressure and the drainage oil temperature.

The drainage oil should have a maximum temperature of 75 °C with a Nitrile shaft seal and 90 °C with a Viton shaft seal. These temperatures must not be exceeded.

The housing pressure must be equal to or greater than the external pressure on the shaft seal.

### Shaft loads

The life of the motor is highly dependent on the bearing life. The bearings are affected by operating conditions such as speed, pressure, oil viscosity and filtration.

External load on the shaft, as well as its size, direction and location also affects the bearing life.

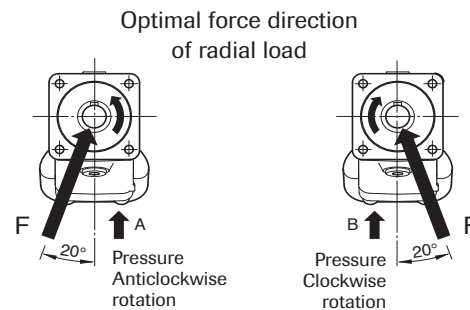
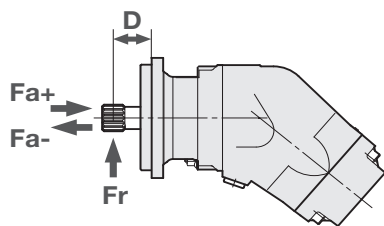

SCM SAE Max recommended shaft loads	010		012		017		025		025		034		034		040		047		056		064		084		084		108		108		130	
	SAE B	SAE B	SAE B	SAE B	SAE B	SAE C	SAE B	SAE C	SAE B	SAE C	SAE C	SAE C	SAE C	SAE C	SAE C	SAE C	SAE C	SAE C	SAE C	SAE C	SAE C	SAE C	SAE C	SAE D	SAE C	SAE D	SAE C	SAE D	SAE D			
Fr (radial) max <sup>1</sup>	kN	6.5	6.5	7	7.5	7.5	7.5	7.5	7	8.5	8.5	8.5	8.5	9	9	9	9	9	9	9	9	9	9	60	45	60	10	10	10.5			
Distance D (to point of force)	mm	40	40	40	40	45	40	45	45	45	45	45	45	45	45	45	45	45	45	45	45	45	60	45	60	45	60	60				
Fa (axial) + (at standstill/ 0 bar pressure) max	kN	3	3	3	3	3	3	3	3	0.5	0.5	0.5	0.5	1	1	1	1	1	1	1	1	1	1	1	1	1	1	1	1			
Fa (axial) - (at standstill/ 0 bar pressure) max	kN	4	4	5	7	7	7	7	7	7	7	7	10	11	13	13	16	16	19													
Fa (axial) + (at 400 bar pressure) max <sup>2</sup>	kN	4	4	5	7	7	7	7	7	7	7	7	10	11	13	13	16	16	19													
Fa (axial) - (at 400 bar pressure) max <sup>2</sup>	kN	0	0	0	0	0	0	0	0	0	0	0	0	0	0	0	0	0	0	0	0	0	0	0	0	0	0	0	0	0		

<sup>1</sup>) Fr (radial) max; Calculation based on running conditions: 300 bar / 2000 rpm

<sup>1</sup>) Fr (radial) max; Calculation based on optimal force direction (Fr max will be lower in other force directions)

<sup>1</sup>) Fr (radial) max; In running conditions higher than 300 bar and/or 2000 rpm the max limits for Fr (radial) max will be lower

<sup>2</sup>) Fa (axial) + Will increase bearing life

<sup>2</sup>) Fa (axial) - Will decrease bearing life

<sup>2</sup>) When having a (high) axial force (Fa+) a sudden fall in pressure can negatively affect bearing life due to lack of compensating load and, if extreme, could lead to bearing failure.

For other forces, please contact Sunfab for advice.

## Temperatures/Housing cooling

Excessive system temperature reduces the life of the shaft seal and can lower the oil viscosity below the recommended level. A system temperature of 60 °C and a drain flow temperature of 90 °C must not be exceeded.

Cooling/flushing of the motor housing can be needed to keep the drain flow temperature at an acceptable level.

### Suggested flow:

Motor SCM	Flushing l/min	Cont. RPM
010-034	2-8	≥ 2800
040-064	4-10	≥ 2500
084-130	6-12	≥ 2200

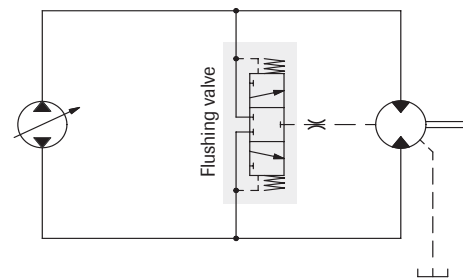
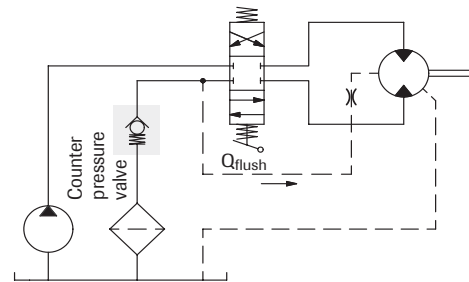
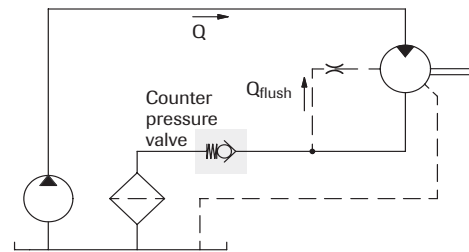
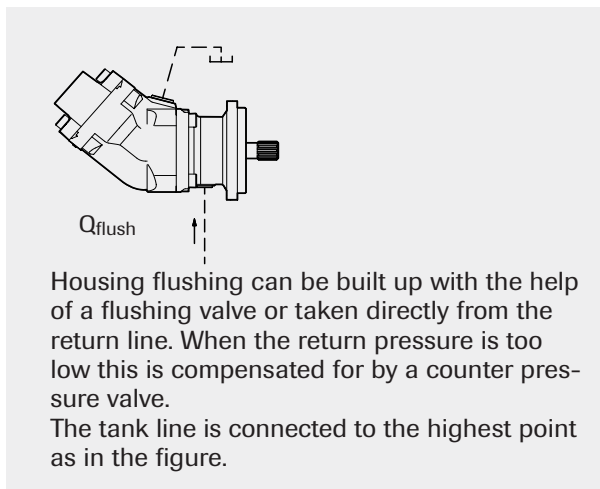

Simplified circuits

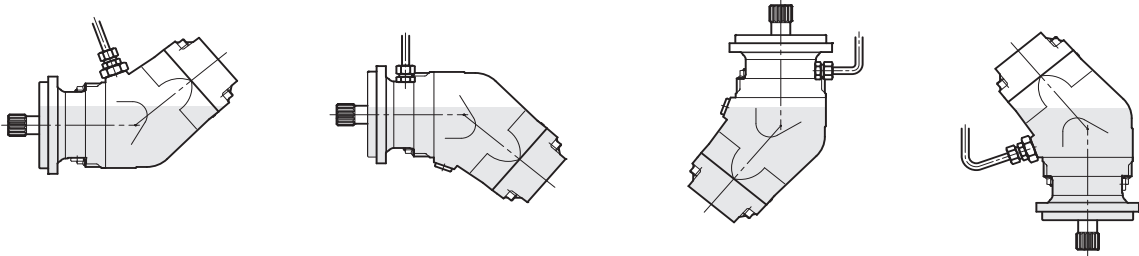

## Installation

- The motor housing should be filled with oil to at least 50% before starting.
- The drainage pipe should be connected to topmost drainage outlet.
- The other end of the pipe should be connected to the oil tank at a point below the oil level.

## Additional technical data

Noise levels and bearing life calculations available on request. Please contact Sunfab!

## Piping

Recommended oil velocity in pressure line max. 7 m/sec

## Filtering

Cleanliness according to ISO norm 4406, code 16/13.

## Hydraulic fluids

High performance oils meeting ISO specifications – such as HM, DIN 51524-2 HLP, or better – must be used.

A min. viscosity of 10 cSt is required to keep the lubrication at a safe level.

The ideal viscosity is 20 - 40 cSt.



## Useful formulaes

$$\text{Required flow rate } Q = \frac{D \times n}{1000 \times \eta_v} \quad \text{litres/min.}$$

$$\text{Speed } n = \frac{Q \times 1000 \times \eta_v}{D} \quad \text{RPM}$$

$$\text{Torque } M = \frac{D \times \Delta p \times \eta_{hm}}{6.3} \quad \text{Nm}$$

$$\text{Power } P = \frac{Q \times \Delta p \times \eta_t}{60} \quad \text{kW}$$

$D$  = displacement, cm<sup>3</sup>/revolution

$n$  = speed, revolution/min

$P$  = power, kW

$Q$  = flow rate, litres/min

$\eta_v$  = volumetric efficiency

$\eta_{hm}$  = hydraulic-mechanical efficiency

$\eta_t$  = overall efficiency =  $\eta_v \times \eta_{hm}$

$M$  = torque, Nm

$\Delta p$  = pressure difference between the hydraulic motor inlet and outlet, MPa



**WARNING**

When the motor is in use:

1. Do not touch the pressure pipe
2. Beware of rotating parts
3. The motor and pipes can reach high temperatures

*Sunfab reserves the right to make changes in design and dimensions without notice. Printing and typesetting errors reserved.*