

ITEM:

TEST SEPARATOR - PIPING

A2648288

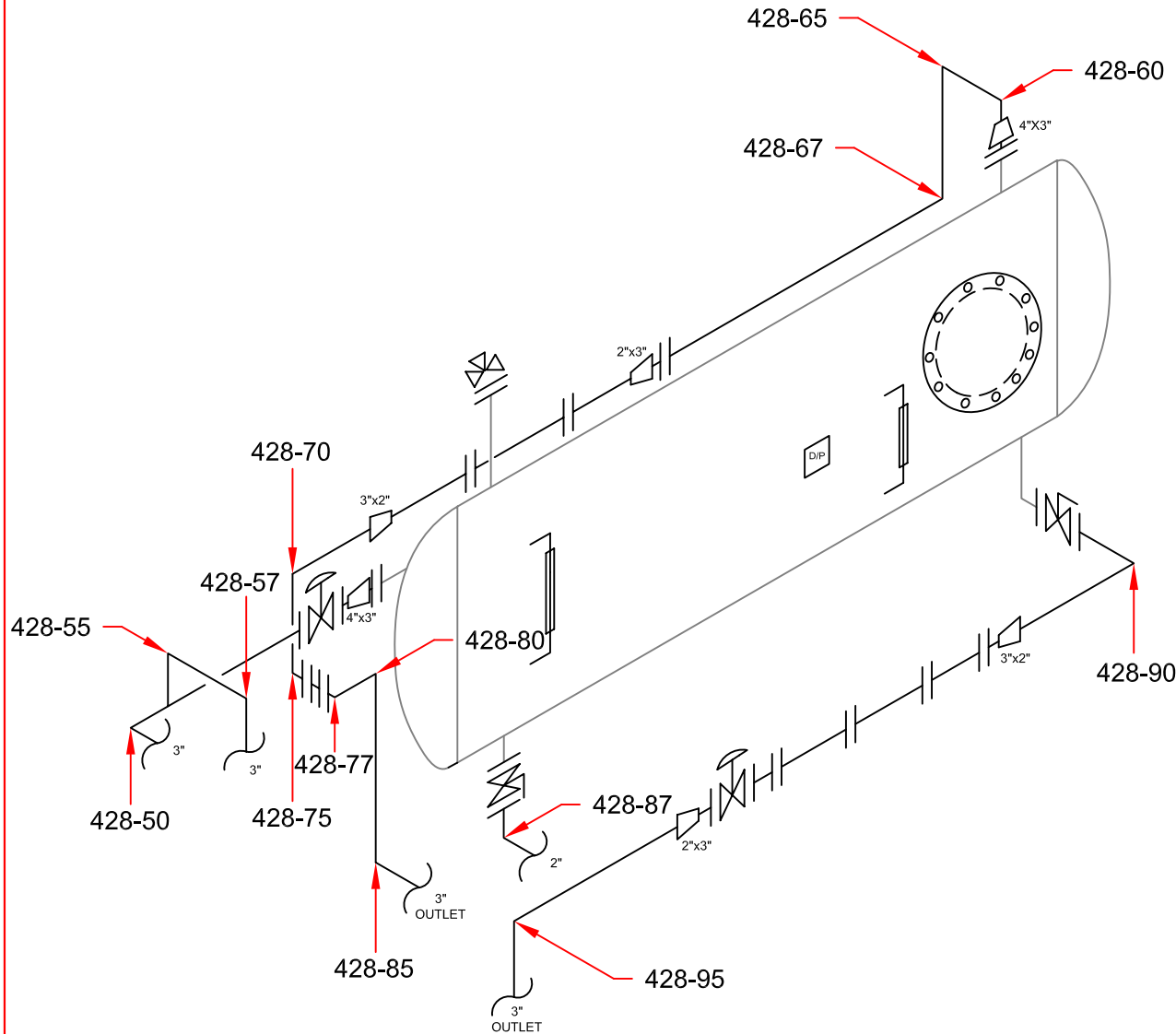

STETTLER, AB (403) 742-4868
 LACOMBE, AB (403) 782-7855
 BROOKS, AB (403) 501-8029
 GRANDE PRAIRIE, AB (866) 422-9732

TECHNICIAN:

STEPHEN KEELEY
 SNT LEVEL II
 CGSB 48.9712
 LEVEL II # 12288

DATE: 02/22/10

DWG # 428A

CLIENT: BARRICK ENERGY

LSD: 10-29-071-23-W5M

INSPECTOR: MWS

LOCATION: STURGEON LAKE NORTH

DISTRICT UNIT: FIELD

BLDG/SKID: PKG54771

PROCESS: SOUR

CODE: ASME B31.3

SPECIFICATION: AS PER ASME SE 797

TECHNIQUE: UT 1-1, REV .1

METHOD: UT CONTINUOUS / A SCAN

SURFACE COND: PAINTED

SURFACE TEMP: AMBIENT

PIPING INFORMATION

PIPING ID	SIZE	SCH	NOM	M.A.W.P. (VESSEL)	M.A.W.T. (VESSEL)	FLANGE RATING
428-50	3.50"	40	.216"	150 PSI	100 °F	600
428-55	"	"	"	"	"	"
428-57	"	"	"	"	"	"
428-60	3.50"	40	.216"	"	"	150
428-65	"	"	"	"	"	"
428-67	"	"	"	"	"	"
428-70	3.50"	40	.216"	"	"	600
428-75	"	"	"	"	"	"
428-77	"	"	"	"	"	"
428-80	"	"	"	"	"	"
428-85	"	"	"	"	"	"
428-87	2.375"	40	.154"	"	"	150
428-90	3.50"	XS	.300"	"	"	"
428-95	"	"	"	"	"	"

COMMENTS:

-

PROJECT:
C40290A