

SPECIFICATIONS

PIPING: A-106-B (SCH.40/80; SMLS)
 FITTINGS: A-105/A-234-WPB
 FLANGES: A-105 (300# RF)
 VALVES: S.S. OR NACE TRIM
 GASKETS: FLEXITALIC (PIPING CONN.)
 STUD/NUTS: A-193-B7M/A-194-2HM
 STEEL TANK: A-38 W
 FAB. CODE: API 12F (MODIFIED)

NOMINAL (USEABLE)	30 BBL (2,590 L)
PRIMARY TANK	7'ø x 5'h
SECONDARY CONTAINMENT	8'ø x 5'h
OVERALL SIZE	8' x 12' x 8"h
ASSEMBLY WEIGHT	4,200 lbs (1,910 Kgs)

ROOF NOZZLES

MARK	SIZE	PROJ	SCH	SPEC	DESCRIPTION	QTY.
M1	24"	5"	-	A36	PRE-FABRICATED MANWAY w/ COVER	1
V1	4"	6"	80	150# RFSO	PRIMARY VENT	1
V2	8"	6"	40	1/4" PL	AUXILIARY VENT w/LID	1
V3	2"	5"	80	MNPT	SECONDARY CONTAINMENT VENT	1
N3	2"	5"	80	MNPT	SPARE ROOF NOZZLE (CAPPED)	1
N4	1.5"	2"	80	F.CPLG	LEVEL GAUGE CONN.	1

SHELL NOZZLES

MARK	SIZE	PROJ	SCH	SPEC	DESCRIPTION	QTY.
N1	3"	6"	80	300# RFSO	LIQUID INLET	1
N2	2"	6"	80	300# RFSO	PUMP OUT/TRUCK OUT	1
N5	2"	4"	80	MNPT	CONTAINMENT DRAIN c/w BALL VALVE	1
N6	1"	1"	80	H.CPLG	OVERFLOW CONN. (PLUGGED)	1
N8	1.5"	1"	80	H.CPLG	CONTAINMENT SITE WINDOW w/ FLOAT BALL	1

NOTES

- 1) PRIMARY TANK (MAX: 16 oz. PRESS; 0.5 oz. VAC)
- 2) SECONDARY CONTAINMENT: MIN. 110% CAPACITY
- 3) TANK EXTERNAL & EXPOSED SKID AREAS SANDBLASTED
 PRIMED & PAINTED TO MEET DEVON SPEC GS-6100-R2
 (LIGHT GREY COLOUR)

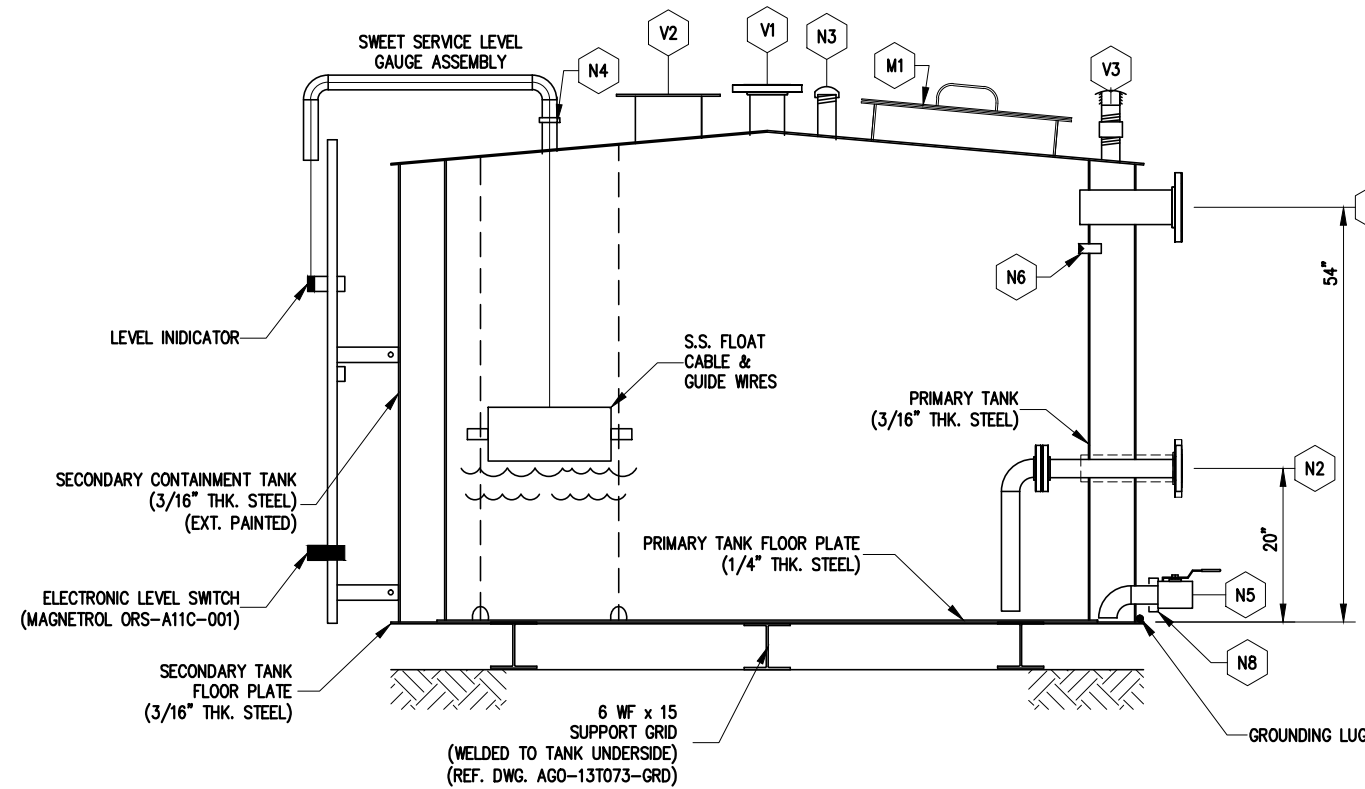

ELEVATION VIEW

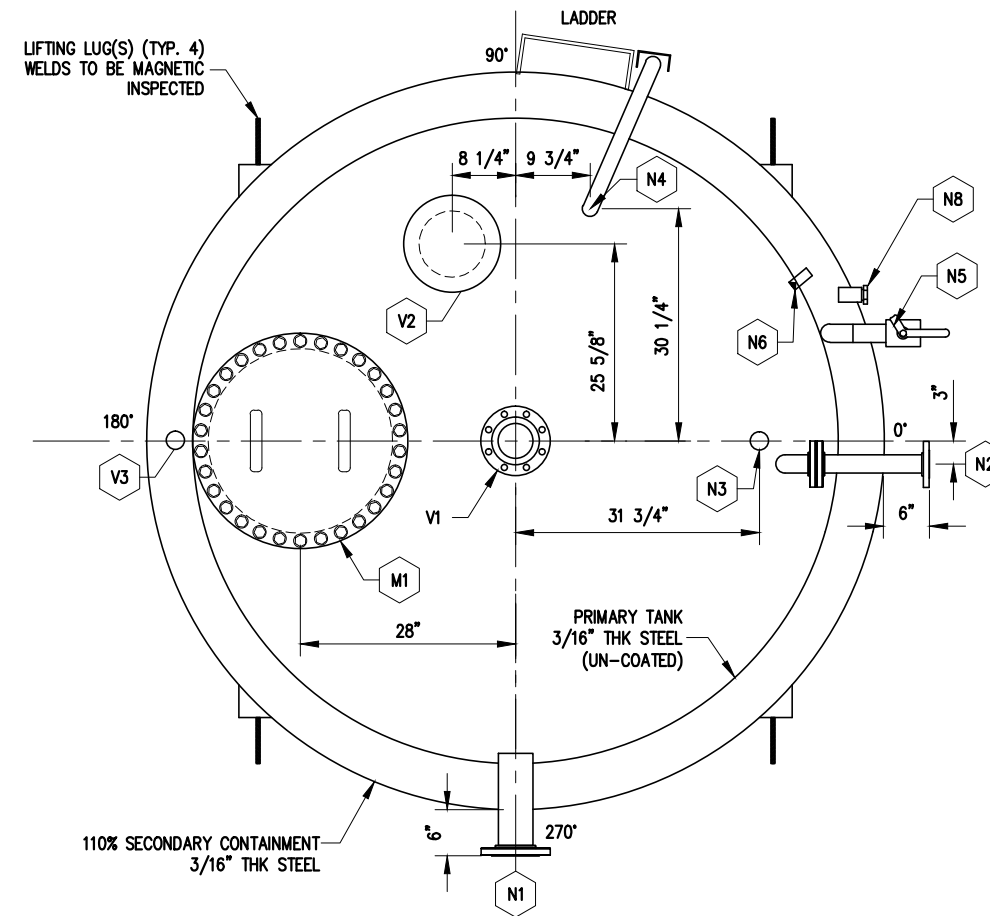

PLAN VIEW

REV	DATE	BY	DESCRIPTION
C	JAN 28/14	LL	APPROVED & ISSUED FOR CONSTRUCTION
B	JAN 17/14	LL	ISSUED FOR APPROVAL
A	SEP 11/13	LL	ISSUED FOR APPROVAL

ALCO GAS & OIL

DEVON CANADA CORP.

30 BBL UNHEATED STORAGE TANK
 WITH INTERGRATED 110% SECONDARY CONTAINMENT
 8426-50 COB UTILITY

SERIAL# 30A13T073
 8426-50 COB UTILITY

Scale: 1:25 Dwg. No.: AGO-13T073

TANKSAFE INC.

CALGARY, ALBERTA, CANADA

ALL RIGHTS RESERVED

