

002-FL-21-1115
HEAT MEDIUM PARTICULATE FILTER
123/4" (324mm) O.D. x 3'-9" (1143mm) 3/8"
213 PSIG D.P. @ -20/356F + 1/16" C.A.
1468 kPag D.P. @ -20/180C + 1.6mm C.A.
(5) POROUS MEDIA 37390, 10 MICRON

001-BMS-21-1101
BURNER MANAGEMENT SYSTEM
SIEMENS LMV52

002-H-21-1110
HEAT MEDIUM HEATER
SASKATOON BOILER JWG-300 GLYCOL/WATER LOW NOX BOILER
DIRECT FIRED, FORCED DRAFT TYPE, THREE PASS
8.08 MM BTU/hr (2362 kW-HR) RATING
250 PSIG D.P. @ -20/410F + 1/16" C.A.
1724 kPag D.P. @ -20/210C + 1.6mm C.A.
BLOWER MOTOR: 15 HP, 575V/3PH/60Hz
NPS18 (457mm) x 11'-4" (3454mm) HIGH STACK
c/w FLAME ARRESTOR
375 USGPM MINIMUM FLOW
(85 cu.mph MINIMUM FLOW)

002-L-21-1184/1185
MANUAL LOUVRES
MANUALLY ADJUSTABLE
48x48 (1219mm x 1219mm)
QTY. OF (2)

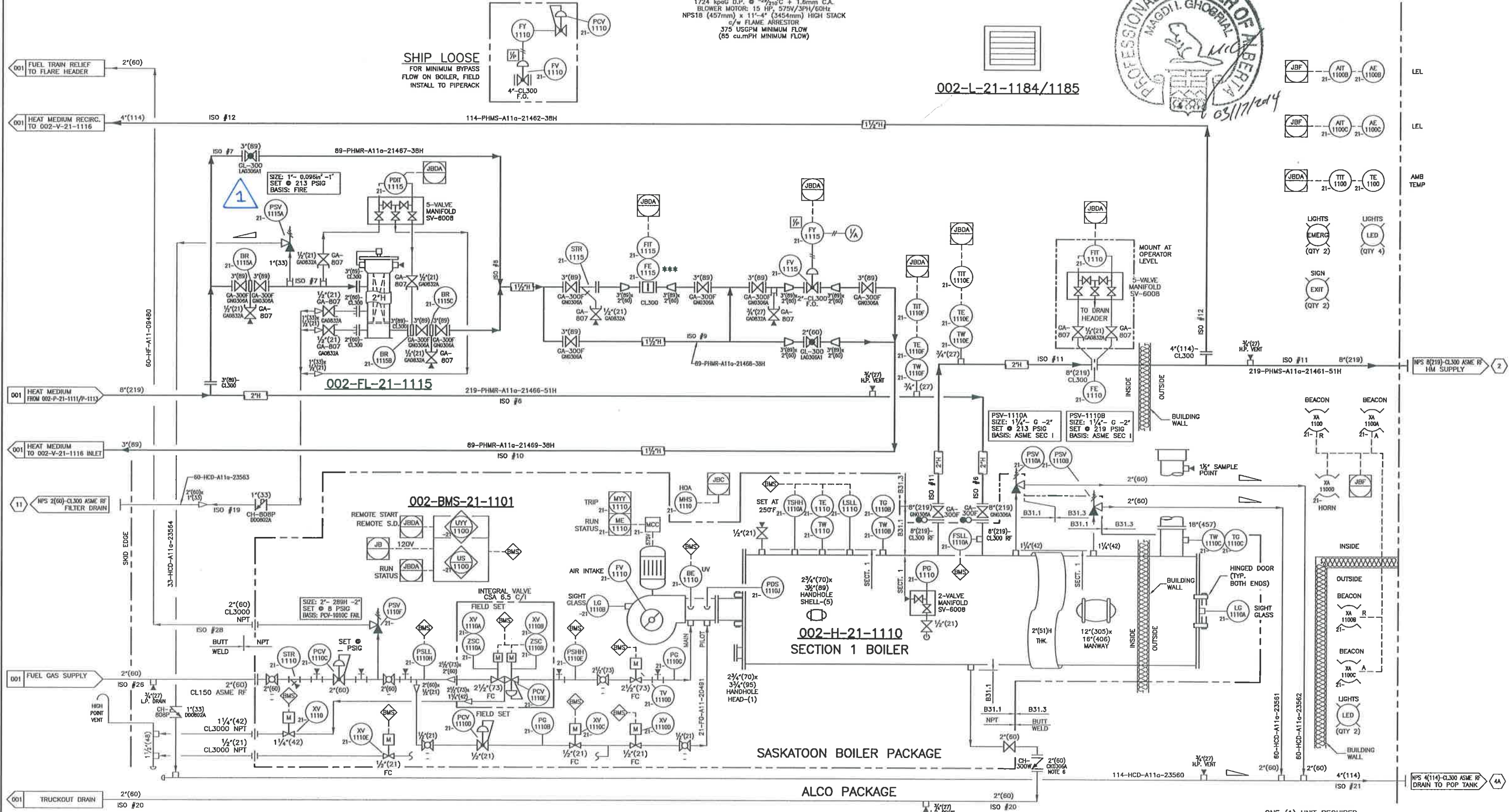

VALVE TAGGING

GA-818

VALVE TYPE: [Symbol] SUFFIX [Symbol]

END CONNECTION: [Symbol]

TRIM: [Symbol]

END CONN.: [Symbol]

SUFFIX: [Symbol]

END CONN.: [Symbol]

TRIM: [Symbol]

END CONN.: [Symbol]

SUFFIX: [Symbol]

END CONN.: [Symbol]

TRIM: [Symbol]

END CONN.: [Symbol]

SUFFIX: [Symbol]

END CONN.: [Symbol]

NOTES:

- * ITEMS SUPPLIED BY SASKATOON BOILER.
- ** ITEMS SUPPLIED BY CLIENT & INSTALLED BY ALCO.
- *** DENOTES METERS REQUIRING A MIN. STRAIGHT PIPE LENGTH OF 10' UPSTREAM & 5' DOWNSTREAM.
- NITROGEN BOTTLES, HOSES AND CONNECTORS SUPPLIED AND INSTALLED BY OTHERS.
- ALL INSTRUMENTS SHALL BE TAGGED AS FOLLOWS:
002-XX-21-XXXX, SO PG-1116 WOULD BE TAGGED:
002-PG-21-1116.
- CH-300W INDICATES A WAFER DUAL PLATE CHECK VALVE.

GENERAL LEGEND:

- DENOTES PNEUMATIC TIE-IN.
- DENOTES PNEUMATIC COMPRESSOR PANEL TIE-IN.
- DENOTES CAPILLARY TIE-IN.
- DENOTES ELECTRICAL TIE-IN (BY OTHERS).
- DENOTES ELECTRICAL JUNCTION BOX TIE-IN.
- DENOTES LOCAL PLC TIE-IN (BY OTHERS).
- DENOTES LOCAL ELECTRICAL PANEL TIE-IN.
- DENOTES FIELD MOUNTED INSTRUMENT.
- DENOTES LOCAL PANEL INSTRUMENT.
- DENOTES LOCAL PANEL INSTRUMENT (MOUNTED INSIDE PANEL).

DWG.	DESCRIPTION	REV.	DATE	BY	CHK'D
0-2013-8426-52A-001/002	LAYOUT/ASSEMBLY	0	2013-03-01	BGR	

ONE (1) UNIT REQUIRED

ALCO GAS & OIL
PRODUCTION EQUIPMENT LTD.

P&ID
PROCESS LEPC DIRECT FIRED HEAT MEDIUM PACKAGE
TAG: 002-PK-21-1100

LOCATION: FERRIER CPF PROJECT
CUSTOMER: DEVON CANADA CORP.

L.S.D. 11-02-038-08 W5M
DWG/SHOP ORDER: D-2013-8426-52F-002/003
REV. 1